

DUE BATTENTI
DOUBLE DOOR
DEUX BATTANTS
ZWEI FLÜGEL

ADRIATICO

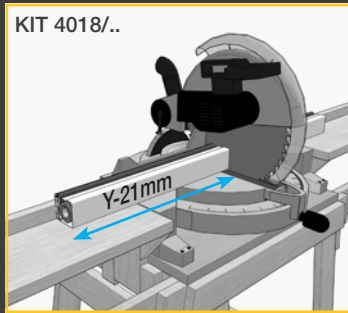

KIT 4018/..
 Taglio cassone da misura foro
 Cutting the cassette from wall to wall
 Coupe caisson de la mesure du trou
 Kastenzuschnitt von der Lichtmasse

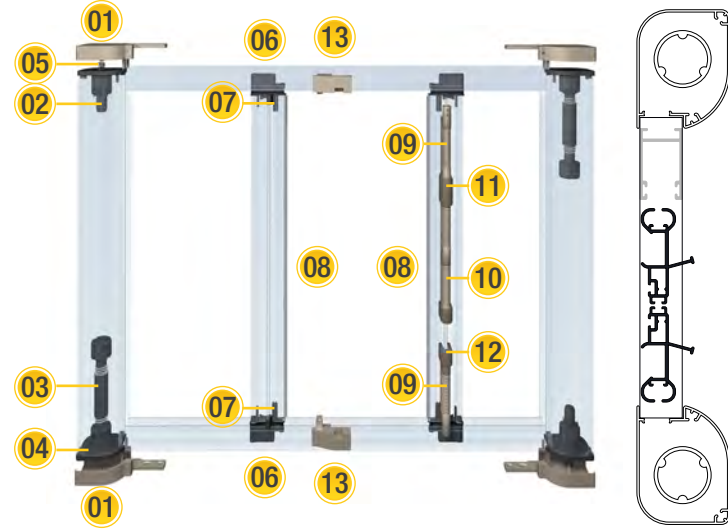
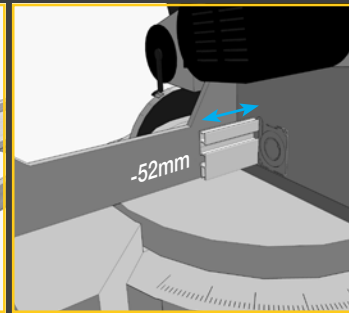

Taglio maniglia dopo taglio cassone
 Cutting the handle after cutting the cassette
 Couper barre poignée apres le coupe caisson
 Griffzuschnitt nach der Kastenzuschnitt

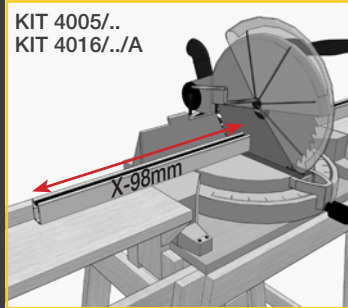

KIT 4005/..
KIT 4016/..A
 Taglio guida da misura foro
 Cutting the guide from wall to wall
 Coupe coulisse de la mesure du trou
 Führungszuschnitt von der Lichtmasse

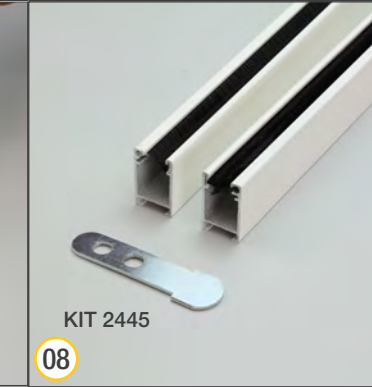
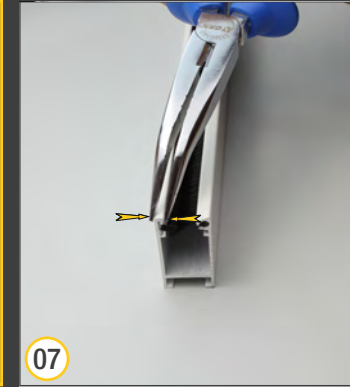
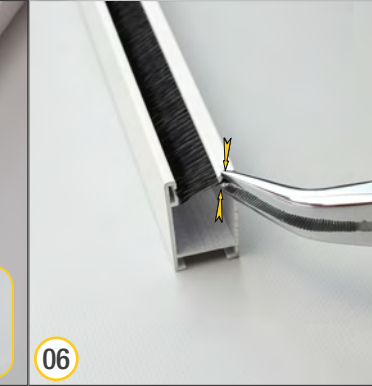
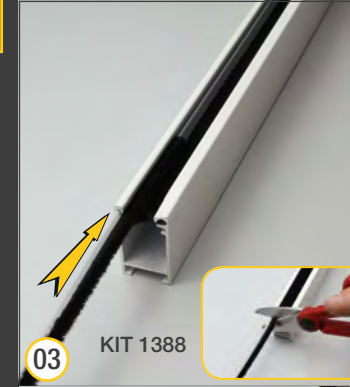
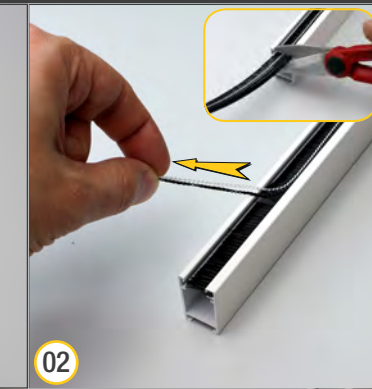

Accessori contenuti nel KIT 4033/... - Accessories contained in the KIT 4033/...
 Accessoires contenus dans le KIT 4033/... - Im Bausatz enthaltenes Zubehör KIT 4033/...

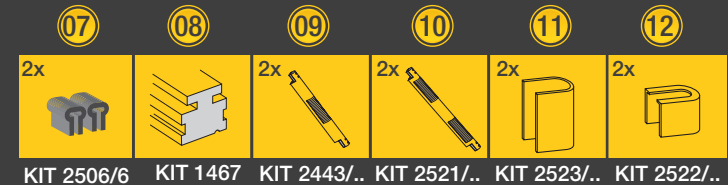

Dimensioni senza frizione Dimensions without brake Dimensions sans frein Abmessungen ohne Bremse		<p>Come rilevare le misure - How to take measurements - Comment prendre les mesures - Anleitung für Massen</p> <p>Considerare solo la misura più piccola del foro architettonico. Consider only the smallest measurement of the opening. Considérer la mesure plus petite. Berücksichtigen das kleinste Maß.</p>
Dimensioni con frizione Dimensions with brake Dimensions avec frein Abmessungen mit Bremse		

Giri molla - Spring windings - Tours ressort - Federwindungen

KIT 2531	8	KIT4005/..
	9	KIT4016/..A
KIT 2540	20	KIT4005/..
	20	KIT4016/..A

Con frizione - with brake - avec frein - mit Bremse **KIT1777: +2**

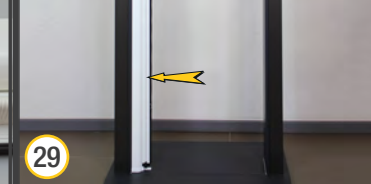
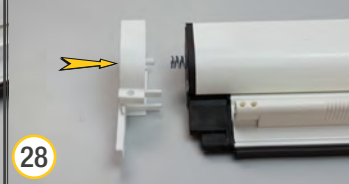
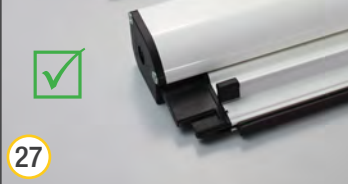
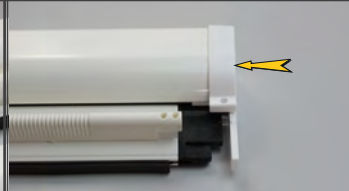
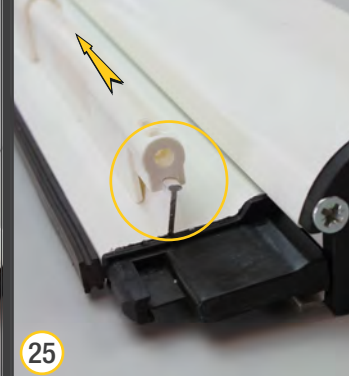
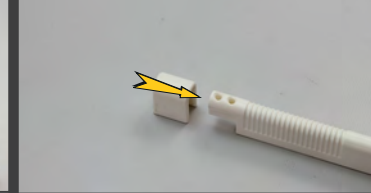
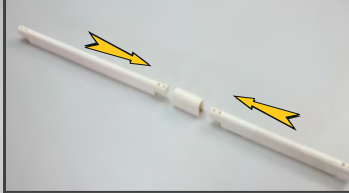
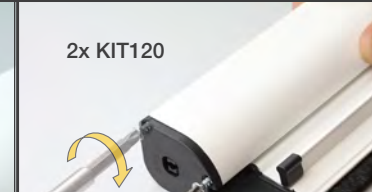
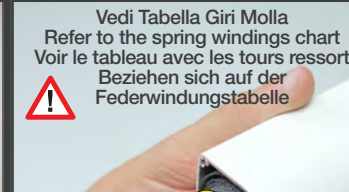
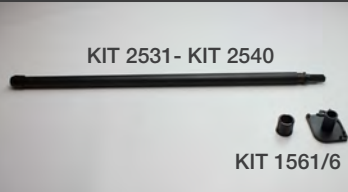
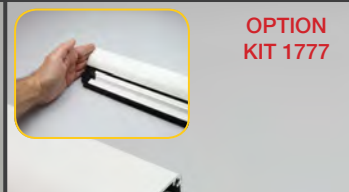
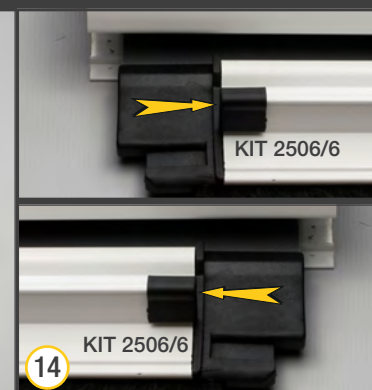
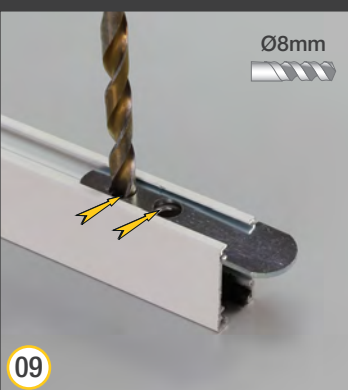

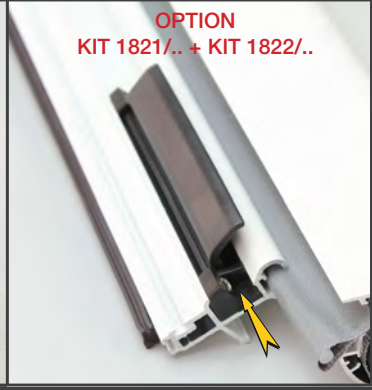
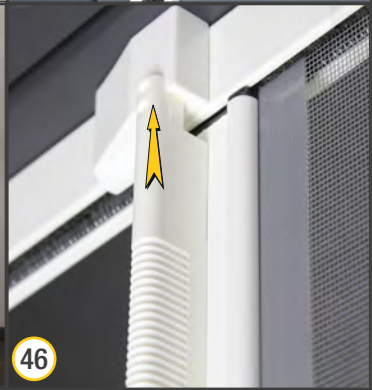
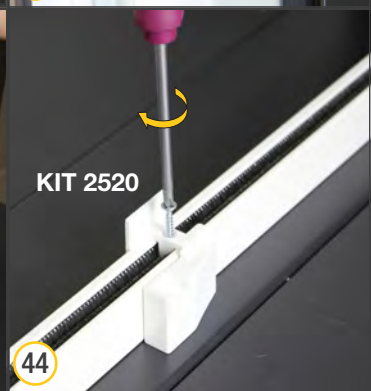
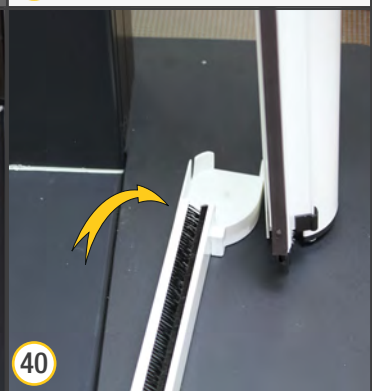
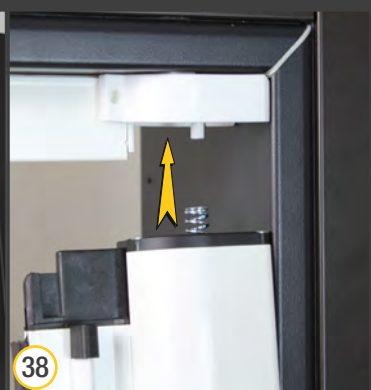
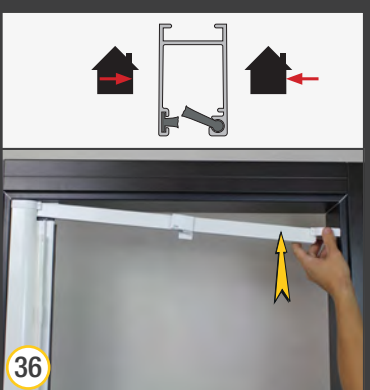
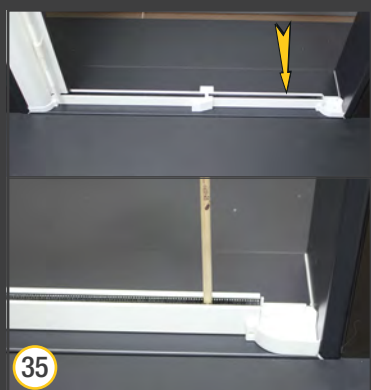
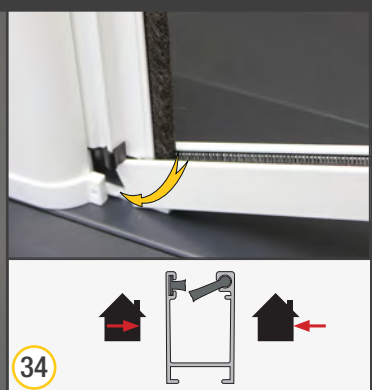

ATTACCO FRONTALE 1
FRONTAL INSTALLATION 1
MONTAGE FRONTAL 1
FRONTALMONTAGE 1

ADRIATICO

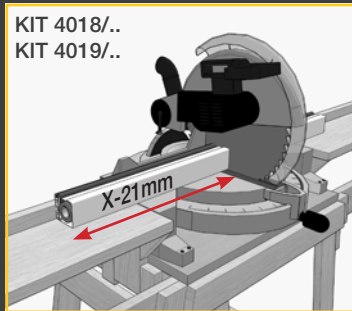
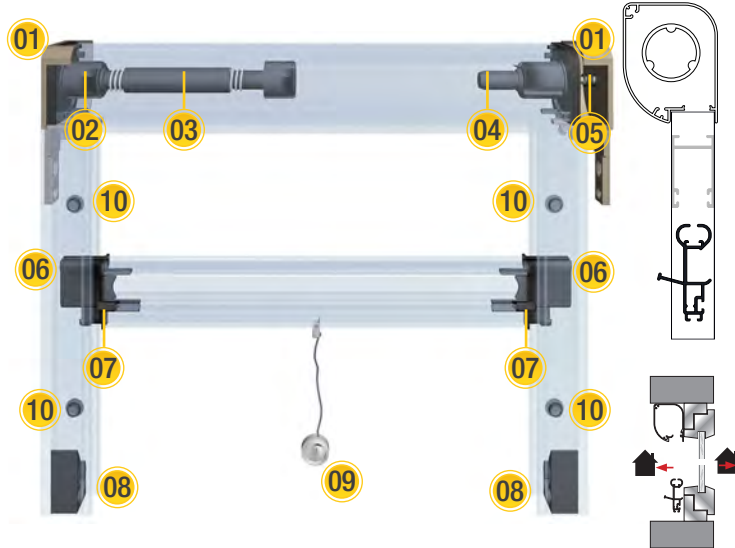

KIT 4018/..
KIT 4019/..
Taglio cassone da misura foro
Cutting the cassette from wall to wall
Coupe caisson de la mesure du trou
Kastenzuschnitt von der Lichtmasse

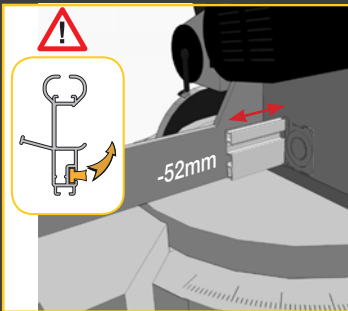

KIT 4005/..
KIT 4016/..A
Taglio maniglia dopo taglio cassone
Cutting the handle after cutting the cassette
Couper barre poignée apres le coupe caisson
Griffzuschnitt nach der Kastenzuschnitt

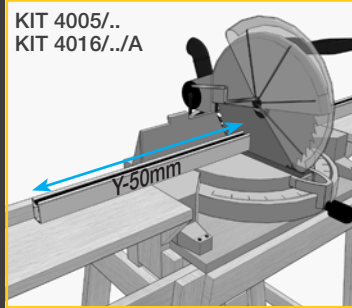

KIT 4005/..
KIT 4016/..A
Taglio guida da misura foro
Cutting the guide from wall to wall
Coupe coulisse de la mesure du trou
Führungszuschnitt von der Lichtmasse

Come rilevare le misure
How to take measurements
Comment prendre les mesures
Anleitung für Massen

Considerare solo la misura più piccola del foro architettonico. Consider only the smallest measurement of the opening. Considérer la mesure plus petite. Berücksichtigen das kleinste Maß.

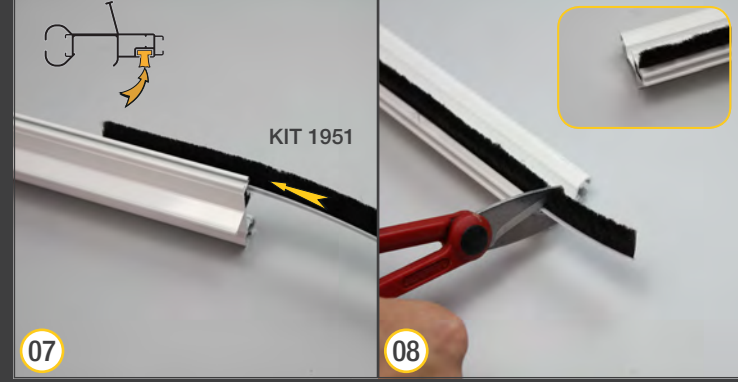
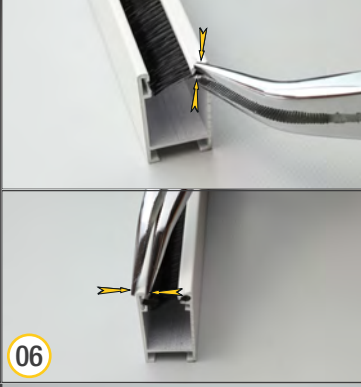
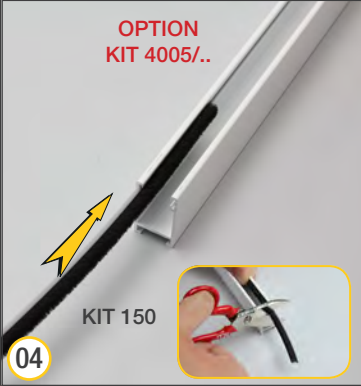
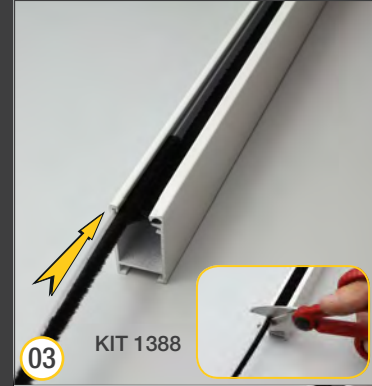

Dimensioni senza frizione Dimensions without brake Dimensions sans frein Abmessungen ohne Bremse		min 550	700	↑
	Finestra Window Fenêtre Fenster	max 2000	1680	↓
	Porta Door Porte Tür	max 1600	2480	↓
Dimensioni con frizione Dimensions with brake Dimensions avec frein Abmessungen mit Bremse		min 750	700	↑
	Finestra Window Fenêtre Fenster	max 2000	1680	↓
	Porta Door Porte Tür	max 1600	2480	↓

Giri molla - Spring windings - Tours ressort - Federwindungen

h	550	600	800	1000	1200	1400	1600	1800	2000	
h. 0-1680	6	6	7	8	10	10	12	15	17	KIT4005/..
	6	7	8	9	11	11	13	16	18	KIT4016/..A
h. 1681-2480	8	8	9	11	13	14	-	-	-	KIT4005/..
	8	9	10	12	14	15	-	-	-	KIT4016/..A

Con frizione - with brake - avec frein - mit Bremse **KIT1777: +2**

Accessori contenuti nel KIT 4031/... - Accessories contained in the KIT 4031/...
Accessoires contenus dans le KIT 4031/... - Im Bausatz enthaltenes Zubehör KIT 4031/...

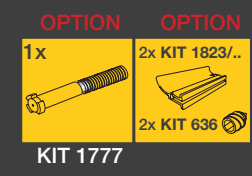

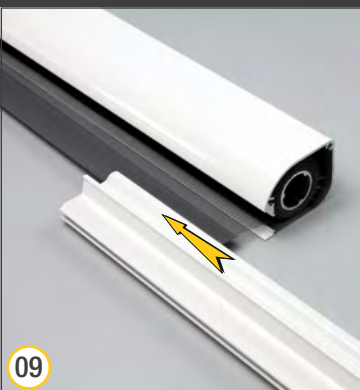

09



10

OPTION
KIT 1777

KIT 2442/6



11

OPTION
KIT 1777



12

2x KIT120



13

KIT 2531

KIT 1561/6



14



15



16

2x KIT120



17

KIT2417/6

KIT2417/6



18

KIT 2506/6

KIT 2506/6

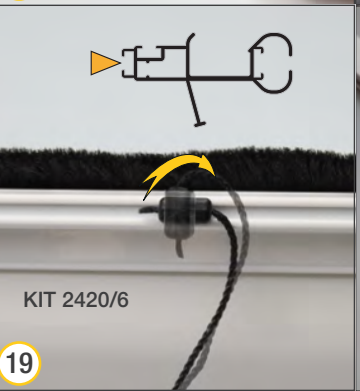

19

KIT 2420/6

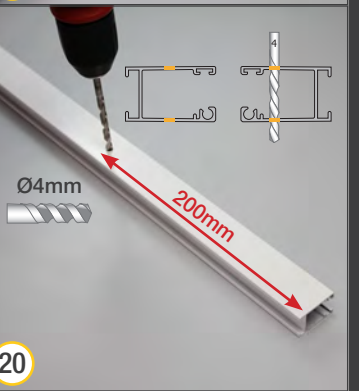

20

Ø4mm

200mm

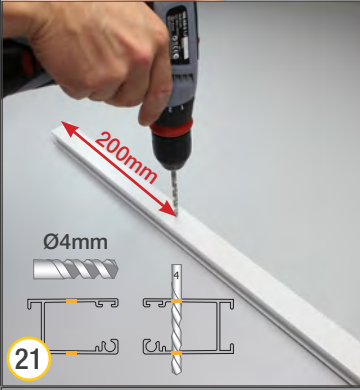

21

Ø4mm

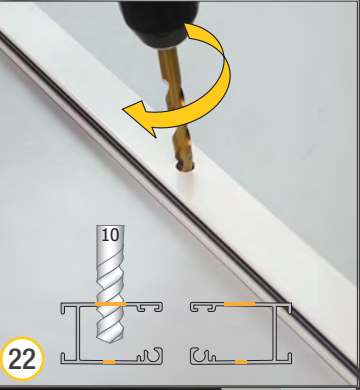

22

10

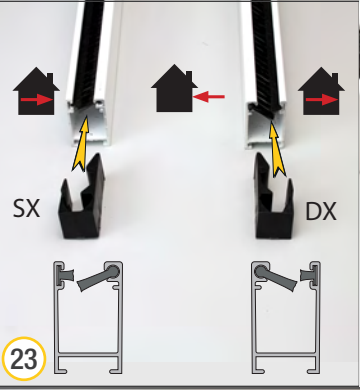

23

SX

DX



24

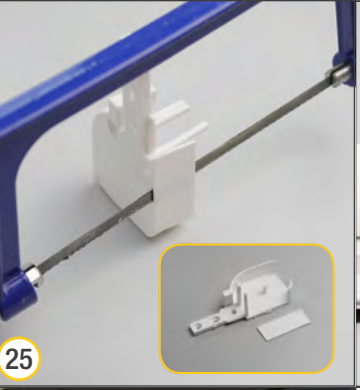

25



26

KIT 2448



27



28



29



30

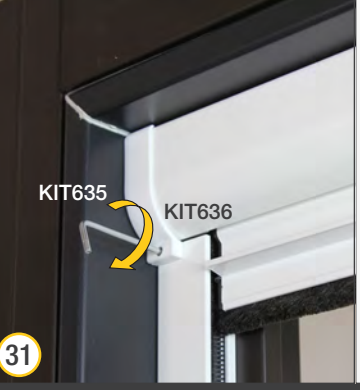

31

KIT635

KIT636

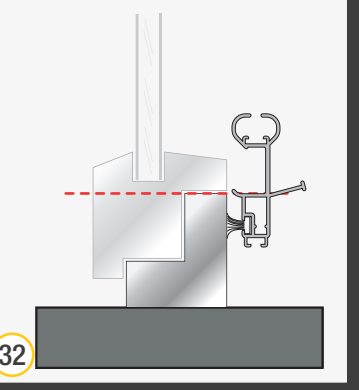

32

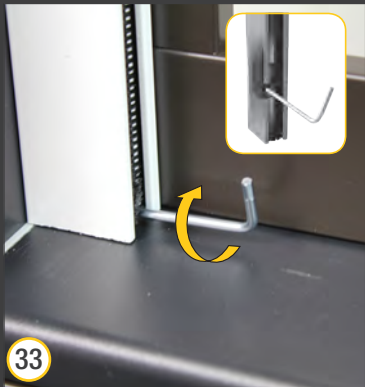

33

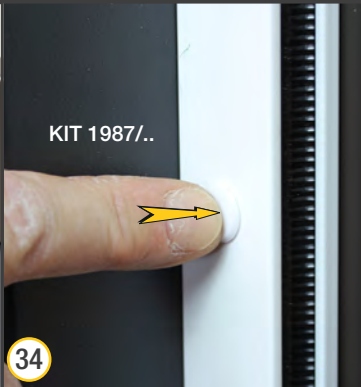

34



35



OPTION KIT 1823/..

ATTACCO FRONTALE 2
FRONTAL INSTALLATION 2
MONTAGE FRONTAL 2
FRONTALMONTAGE 2

ADRIATICO

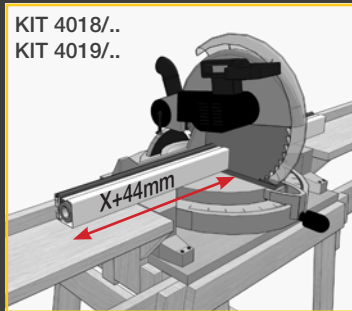
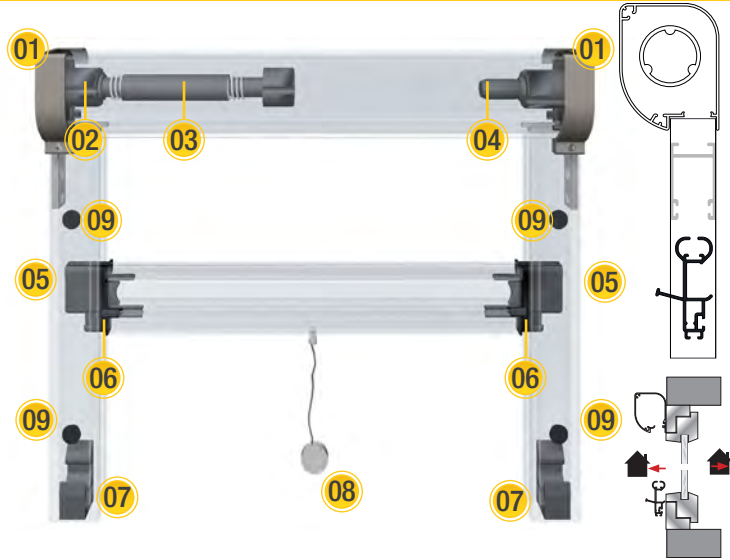

Taglio cassone da misura foro
 Cutting the cassette from wall to wall
 Coupe caisson de la mesure du trou
 Kastenzuschnitt von der Lichtmasse

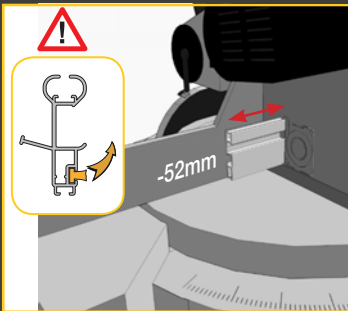

Taglio maniglia dopo taglio cassone
 Cutting the handle after cutting the cassette
 Couper barre poignée après le coupe caisson
 Griffzuschnitt nach der Kastenzuschnitt

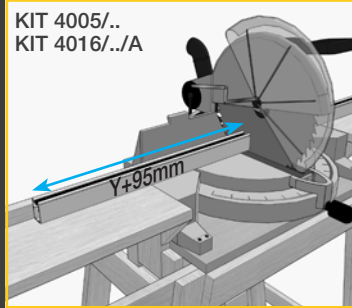

Taglio guida da misura foro
 Cutting the guide from wall to wall
 Coupe coulisse de la mesure du trou
 Führungszuschnitt von der Lichtmasse

Come rilevare le misure
 How to take measurements
 Comment prendre les mesures
 Anleitung für Massen

Considerare solo la misura più piccola del foro architettonico. Consider only the smallest measurement of the opening. Considérer la mesure plus petite. Berücksichtigen das kleinste Maß.

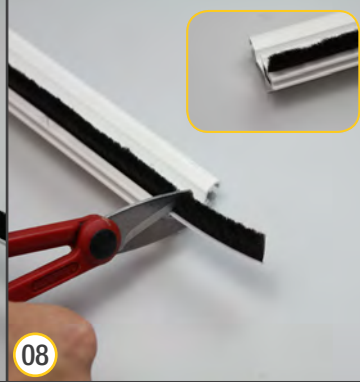
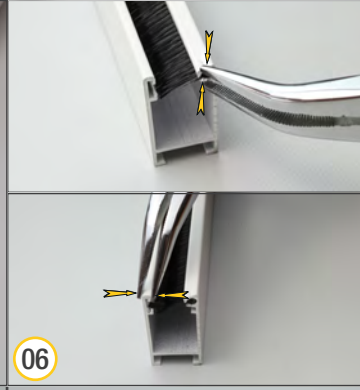
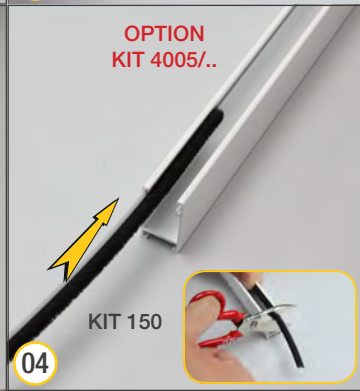
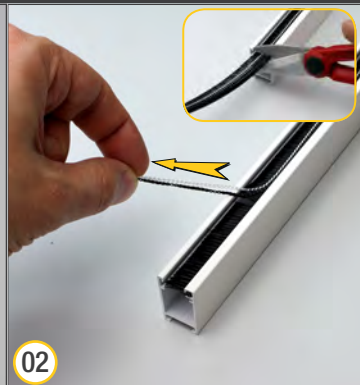
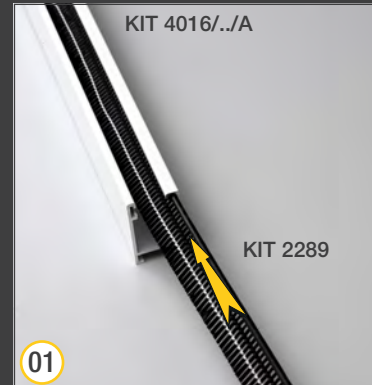

Dimensioni senza frizione Dimensions without brake Dimensions sans frein Abmessungen ohne Bremse	Finestra Window Fenêtre Fenster Porta Door Porte Tür	min 550 max 2000	700 1680
Dimensioni con frizione Dimensions with brake Dimensions avec frein Abmessungen mit Bremse	Finestra Window Fenêtre Fenster Porta Door Porte Tür	min 750 max 2000	700 1680

Giri molla - Spring windings - Tours ressort - Federwindungen

	550	600	800	1000	1200	1400	1600	1800	2000	
h. 0-1680	6	6	7	8	10	10	12	15	17	KIT4005/..
	6	7	8	9	11	11	13	16	18	KIT4016/..A
h. 1681-2480	8	8	9	11	13	14	-	-	-	KIT4005/..
	8	9	10	12	14	15	-	-	-	KIT4016/..A

Con frizione - with brake - avec frein - mit Bremse KIT1777: +2

Accessori contenuti nel KIT 4031/... - Accessories contained in the KIT 4031/...
 Accessoires contenus dans le KIT 4031/... - Im Bausatz enthaltenes Zubehör KIT 4031/...

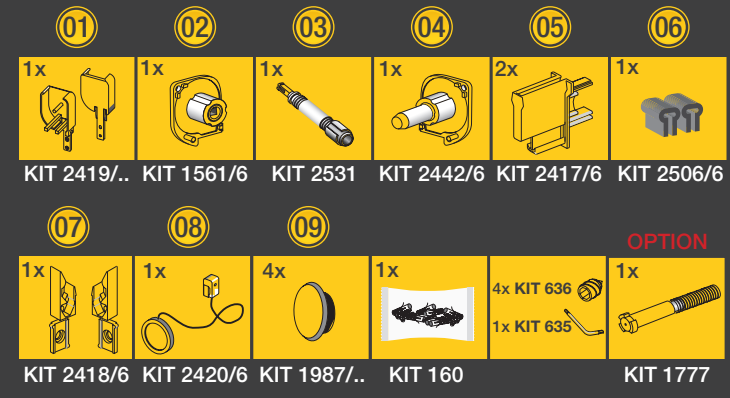



09



10



11



12



13



14



15



16

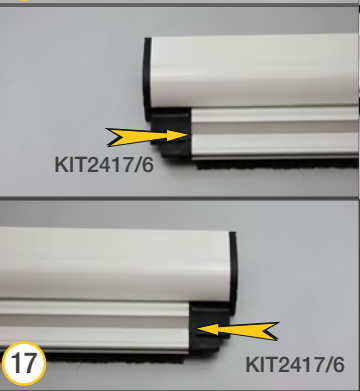

17



18

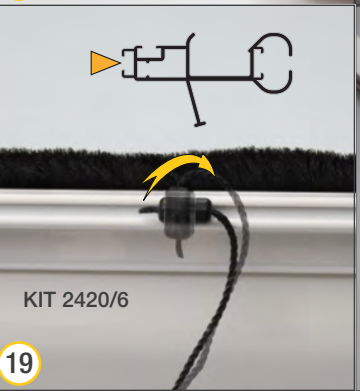

19

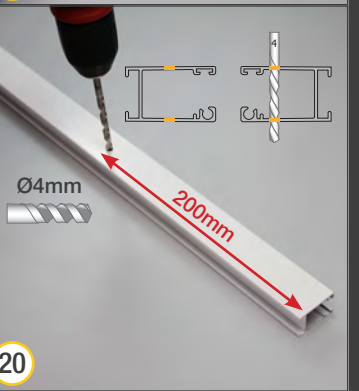

20

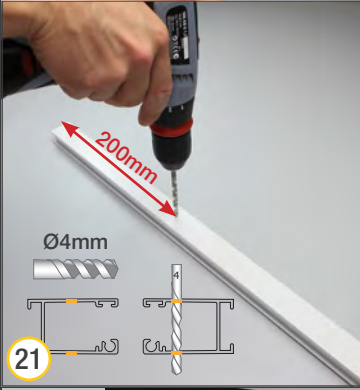

21

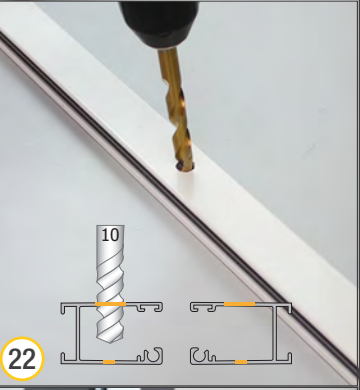

22

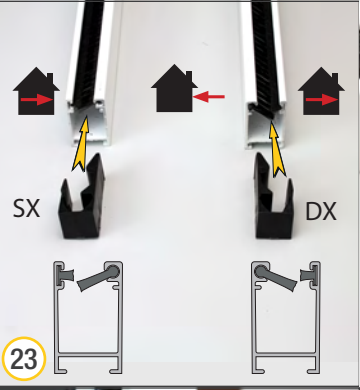

23

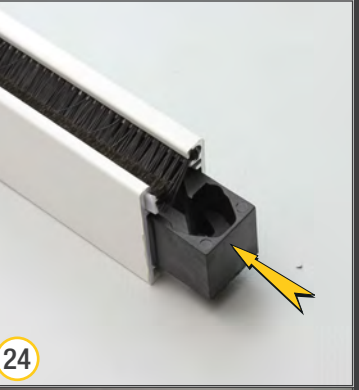

24

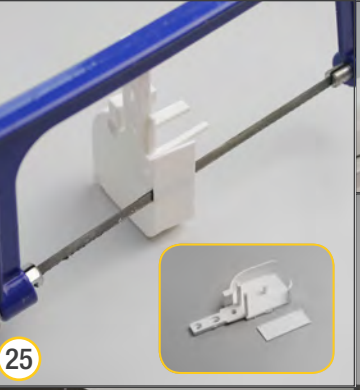

25



26



27



28



29



30



31



32

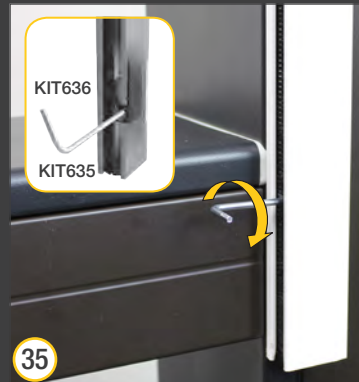
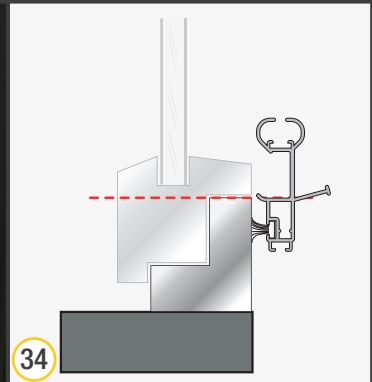

ATTACCO FRONTALE 3
FRONTAL INSTALLATION 3
MONTAGE FRONTAL 3
FRONTALMONTAGE 3

ADRIATICO

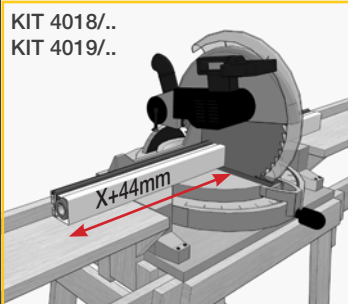
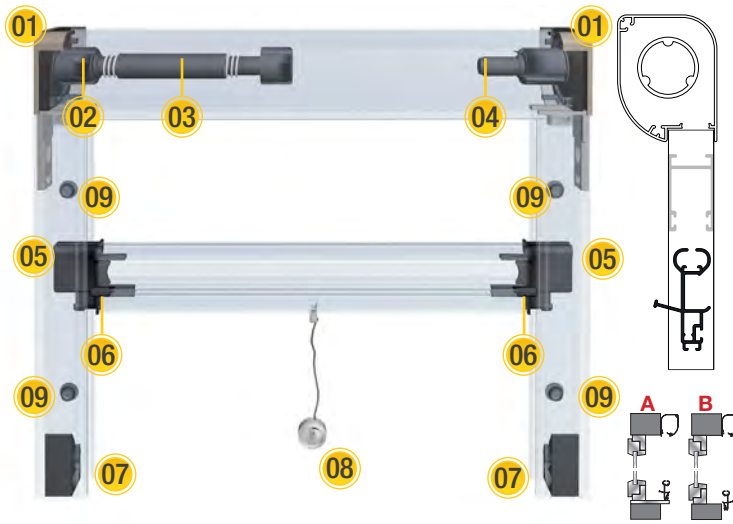

KIT 4018/..
KIT 4019/..
Taglio cassone da misura foro
Cutting the cassette from wall to wall
Coupe caisson de la mesure du trou
Kastenzuschnitt von der Lichtmasse

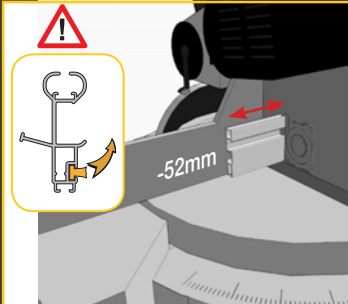

Taglio maniglia dopo taglio cassone
Cutting the handle after cutting the cassette
Couper barre poignée après le coupe caisson
Griffzuschnitt nach der Kastenzuschnitt

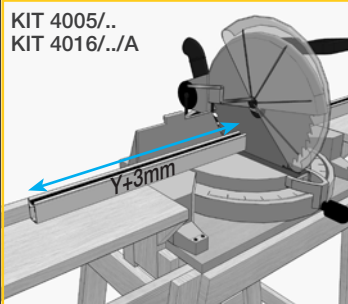

KIT 4005/..
KIT 4016/..A
Taglio guida da misura foro
Cutting the guide from wall to wall
Coupe coulisse de la mesure du trou
Führungszuschnitt von der Lichtmasse

Come rilevare le misure
How to take measurements
Comment prendre les mesures
Anleitung für Massen

Considerare solo la misura più piccola del foro architettonico. Consider only the smallest measurement of the opening. Considérer la mesure plus petite. Berücksichtigen das kleinste Maß.

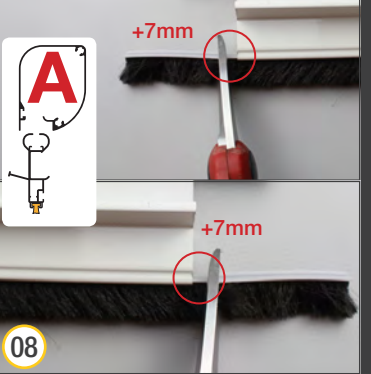
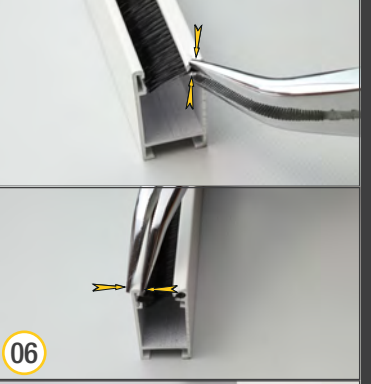
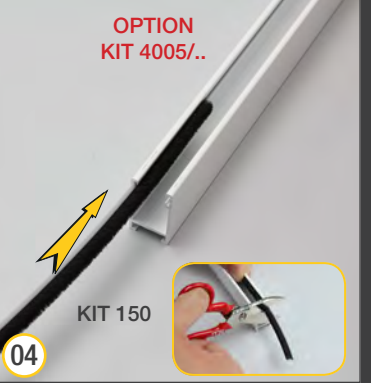
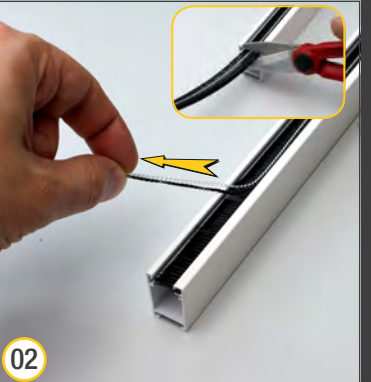
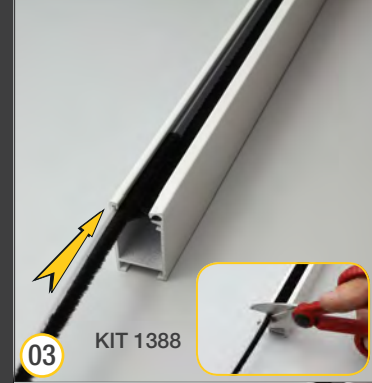
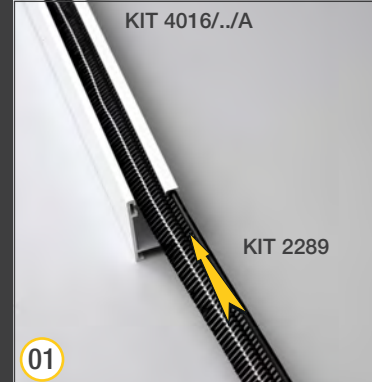

Accessori contenuti nel KIT 4031/... - Accessories contained in the KIT 4031/...
Accessoires contenus dans le KIT 4031/... - Im Bausatz enthaltenes Zubehör KIT 4031/...



Dimensioni senza frizione Dimensions without brake Dimensions sans frein Abmessungen ohne Bremse		min 550	700	↑
	Finestra Window Fenêtre Fenster	max 2000	1680	↓
	Porta Door Porte Tür	max 1600	2480	↓
Dimensioni con frizione Dimensions with brake Dimensions avec frein Abmessungen mit Bremse		min 750	700	↑
	Finestra Window Fenêtre Fenster	max 2000	1680	↓
	Porta Door Porte Tür	max 1600	2480	↓

Giri molla - Spring windings - Tours ressort - Federwindungen

h	550	600	800	1000	1200	1400	1600	1800	2000	
h. 0-1680	6	6	7	8	10	10	12	15	17	KIT4005/..
	6	7	8	9	11	11	13	16	18	KIT4016/..A
h. 1681-2480	8	8	9	11	13	14	-	-	-	KIT4005/..
	8	9	10	12	14	15	-	-	-	KIT4016/..A

Con frizione - with brake - avec frein - mit Bremse **KIT1777: +2**



09

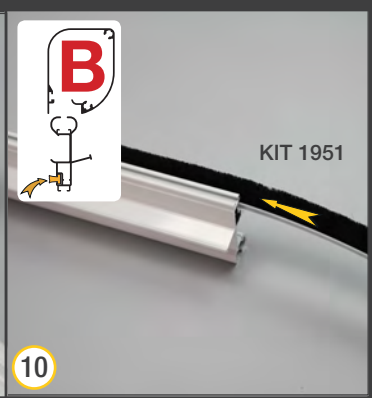

10

KIT 1951

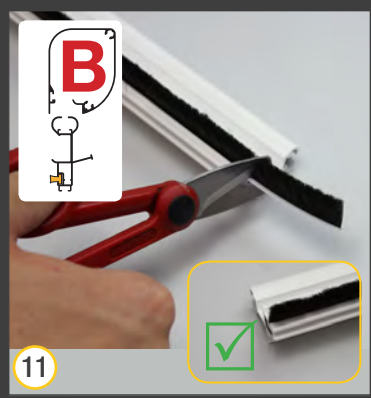

11



12



13

OPTION
KIT 1777

KIT 2442/6

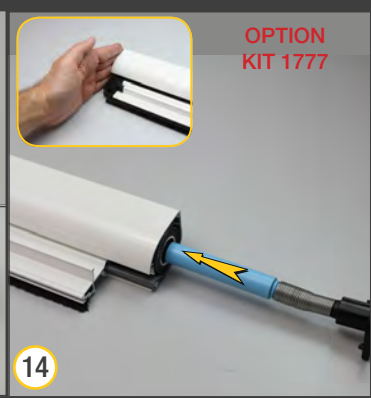

14

OPTION
KIT 1777



15

2x KIT120



16

KIT 2531

KIT 1561/6

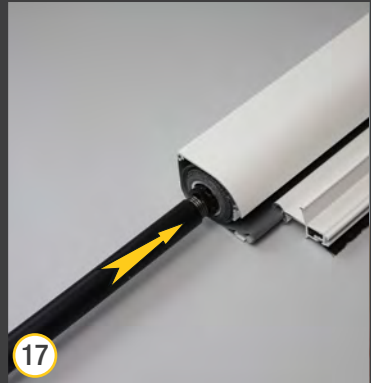

17



18

! Vedi Tabella Giri Molla
Refer to the spring windings chart
Voir le tableau avec les tours ressort
Beziehen sich auf der
Federwindungstabelle



19

2x KIT120

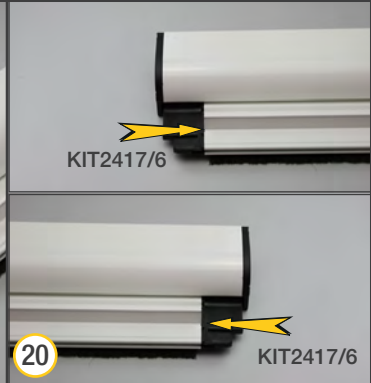

20

KIT2417/6

KIT2417/6



21

KIT 2506/6

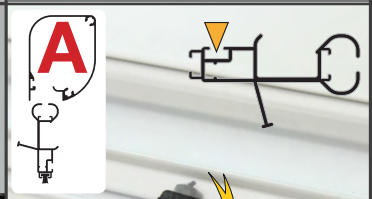

22

KIT 2420/6

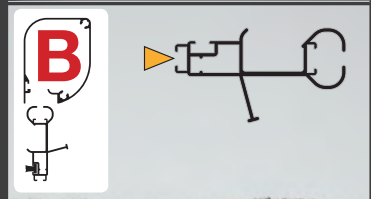

23

KIT 2420/6

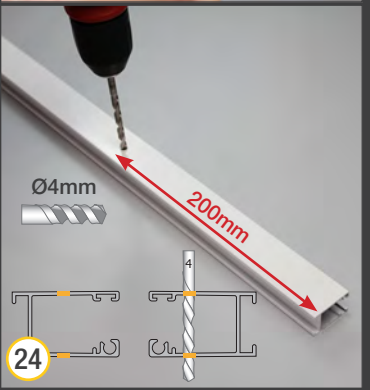

24

Ø4mm

200mm

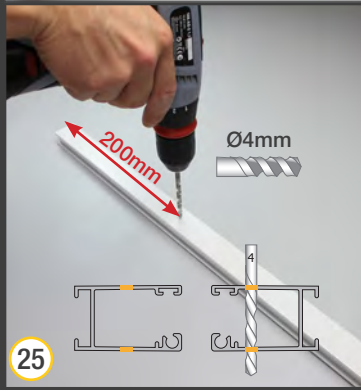

25

200mm

Ø4mm

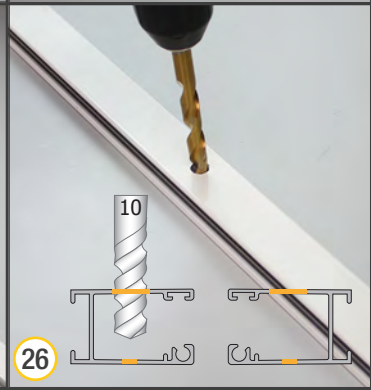

26

10



27

SX

DX

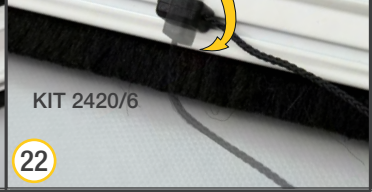

28



29

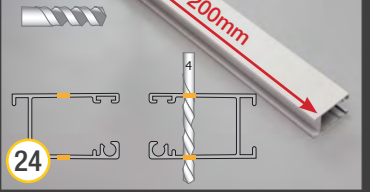

30

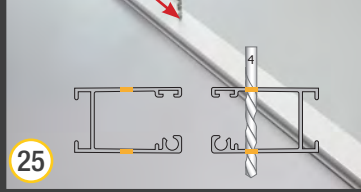

31

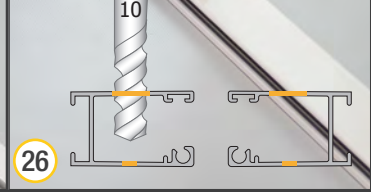

32

Ø6mm



33



34



35



36

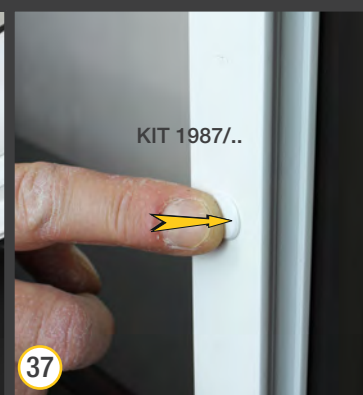

37

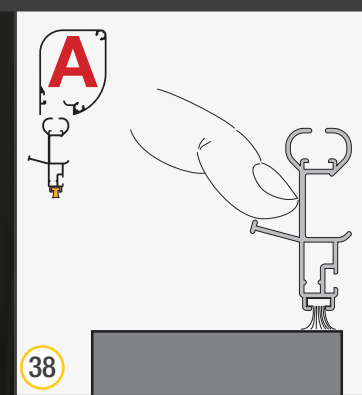

38



39

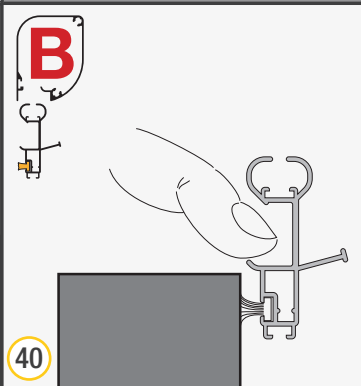

40



41



42



OPTION KIT 1823/..

OPTION KIT 1823/..

ZOCCOLI ESTERNI
EXTERNAL SHOES
ARRÊT EXTERNE
AUSSENSOCKEL

ADRIATICO

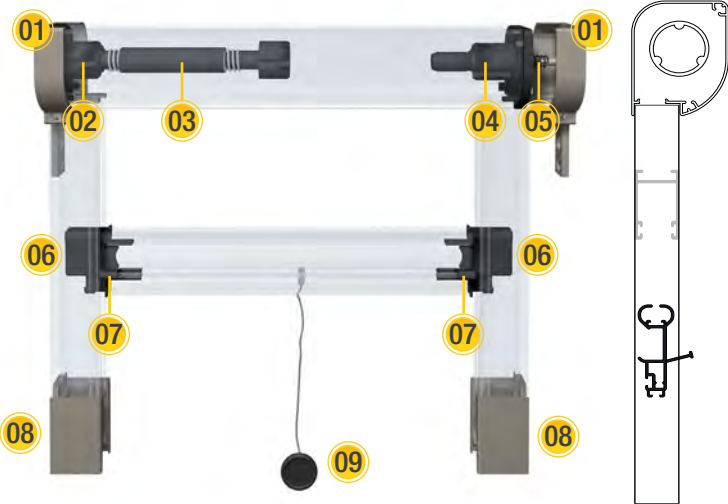

Accessori contenuti nel KIT 4031/... - Accessories contained in the KIT 4031/...
Accessoires contenus dans le KIT 4031/... - Im Bausatz enthaltenes Zubehör KIT 4031/...

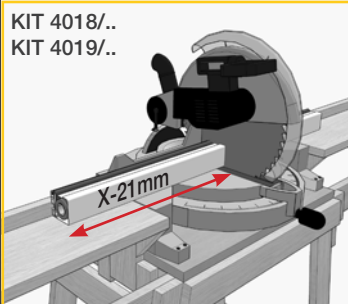

KIT 4018/..
KIT 4019/..

Taglio cassone da misura foro
Cutting the cassette from wall to wall
Coupe caisson de la mesure du trou
Kastenzuschnitt von der Lichtmasse

-21 mm

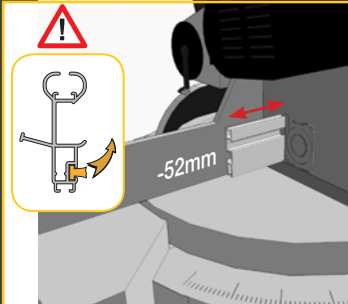

Taglio maniglia dopo taglio cassone
Cutting the handle after cutting the cassette
Couper barre poignée apres le coupe caisson
Griffzuschnitt nach der Kastenzuschnitt

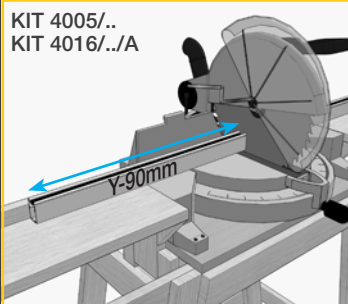

KIT 4005/..
KIT 4016/.., /A

Taglio guida da misura foro
Cutting the guide from wall to wall
Coupe coulisse de la mesure du trou
Führungszuschnitt von der Lichtmasse

-90 mm

Come rilevare le misure
How to take measurements
Comment prendre les mesures
Anleitung für Messen

Considerare solo la misura più piccola del foro architettonico. Consider only the smallest measurement of the opening. Considérer la mesure plus petite. Berücksichtigen das kleinste Maß.

Dimensioni senza frizione Dimensions without brake Dimensions sans frein Abmessungen ohne Bremse	Finestra Window Fenêtre Fenster Porta Door Porte Tür	min 550 max 2000	700 1680
Dimensioni con frizione Dimensions with brake Dimensions avec frein Abmessungen mit Bremse	Finestra Window Fenêtre Fenster Porta Door Porte Tür	min 750 max 2000	700 1680

Giri molla - Spring windings - Tours ressort - Federwindungen

h	550	600	800	1000	1200	1400	1600	1800	2000
h. 0-1680	6	6	7	8	10	10	12	15	17
	6	7	8	9	11	11	13	16	18
h. 1680-2480	8	8	9	11	13	14	-	-	-
	8	9	10	12	14	15	-	-	-

Con frizione - with brake - avec frein - mit Bremse **KIT1777: +2**

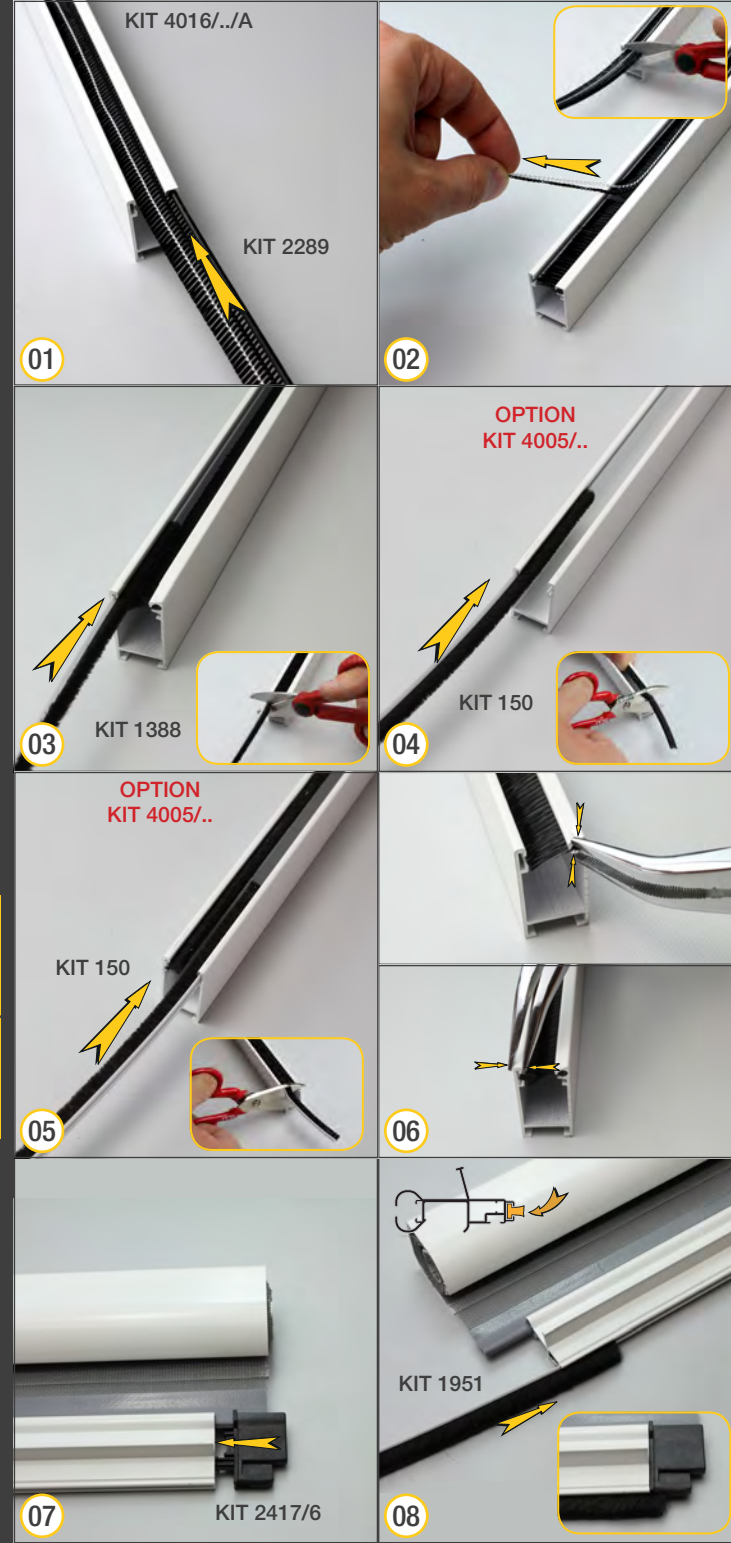

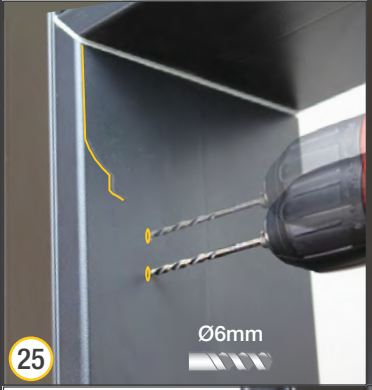
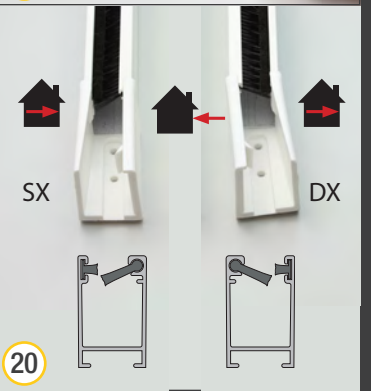
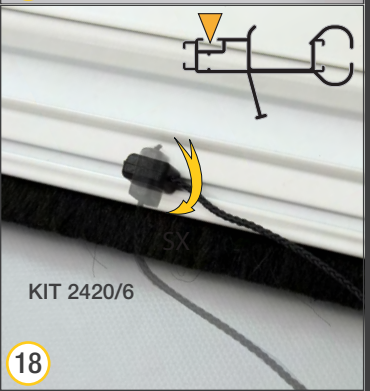
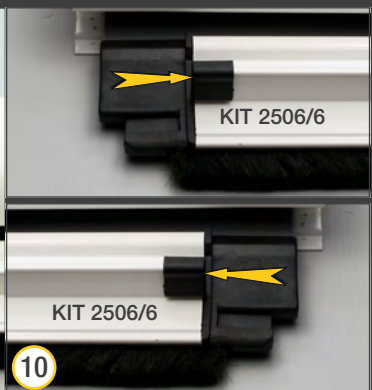
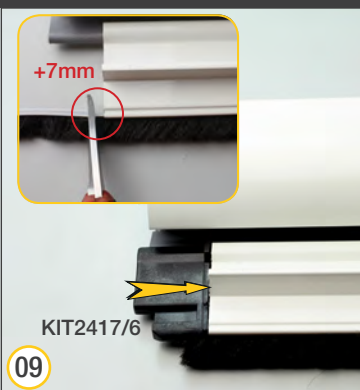



ZOCCOLI INTERNI
 INSIDE SHOES
 ARRÊT INTERNE
 INNENSOCKEL

ADRIATICO

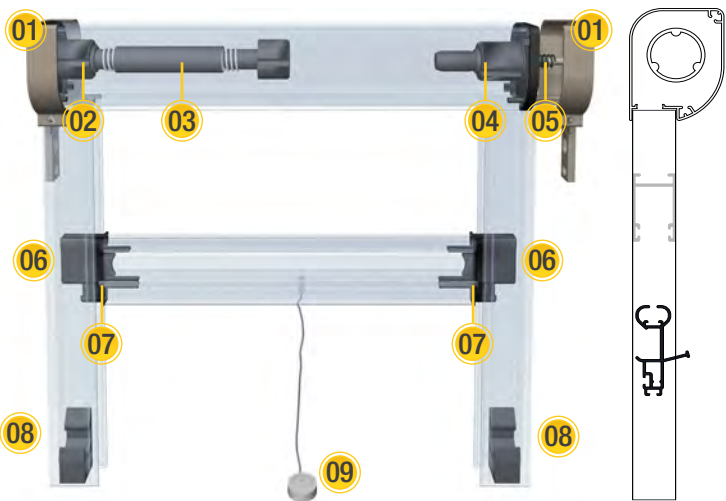

Accessori contenuti nel KIT 4031/... - Accessories contained in the KIT 4031/...
 Accessoires contenus dans le KIT 4031/... - Im Bausatz enthaltenes Zubehör KIT 4031/...

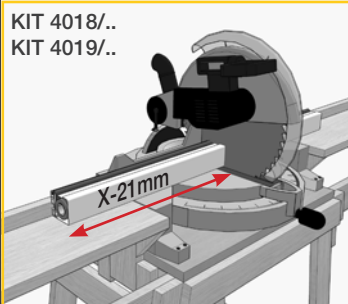
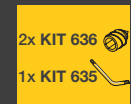
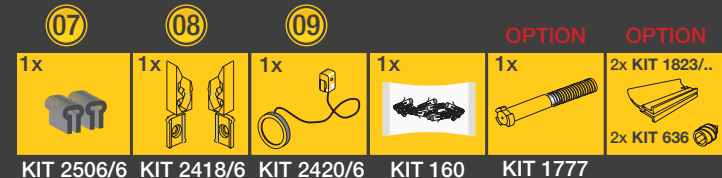
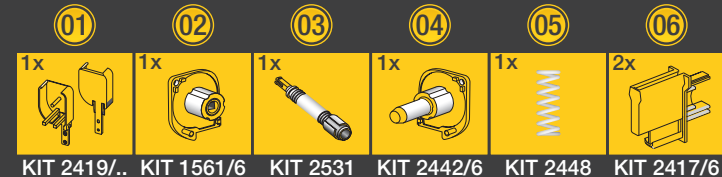

Taglio cassone da misura foro
 Cutting the cassette from wall to wall
 Coupe caisson de la mesure du trou
 Kastenzuschnitt von der Lichtmasse

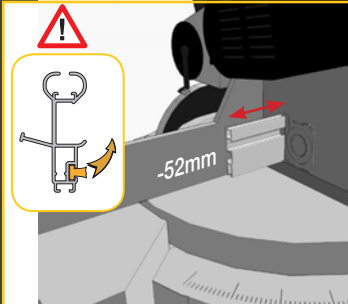

Taglio maniglia dopo taglio cassone
 Cutting the handle after cutting the cassette
 Couper barre poignée après le coupe caisson
 Griffzuschnitt nach der Kastenzuschnitt

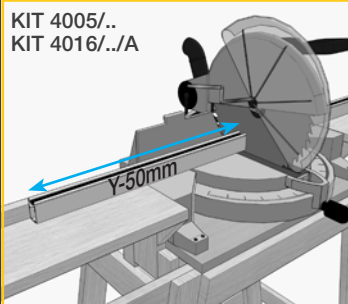

Taglio guida da misura foro
 Cutting the guide from wall to wall
 Coupe coulisse de la mesure du trou
 Führungszuschnitt von der Lichtmasse

Come rilevare le misure
 How to take measurements
 Comment prendre les mesures
 Anleitung für Messen

Considerare solo la misura più piccola del foro architettonico. Consider only the smallest measurement of the opening. Considérer la mesure plus petite. Berücksichtigen das kleinste Maß.

Dimensioni senza frizione Dimensions without brake Dimensions sans frein Abmessungen ohne Bremse	Finestra Window Fenêtre Fenster Porta Door Porte Tür	min 550 max 2000	700 1680
Dimensioni con frizione Dimensions with brake Dimensions avec frein Abmessungen mit Bremse	Finestra Window Fenêtre Fenster Porta Door Porte Tür	min 750 max 2000	700 1680

Giri molla - Spring windings - Tours ressort - Federwindungen

h	550	600	800	1000	1200	1400	1600	1800	2000	
h. 0-1680	6	6	7	8	10	10	12	15	17	KIT4005/.. KIT4016/..A
	6	7	8	9	11	11	13	16	18	
h. 1680-2480	8	8	9	11	13	14	-	-	-	
	8	9	10	12	14	15	-	-	-	

Con frizione - with brake - avec frein - mit Bremse KIT1777: +2

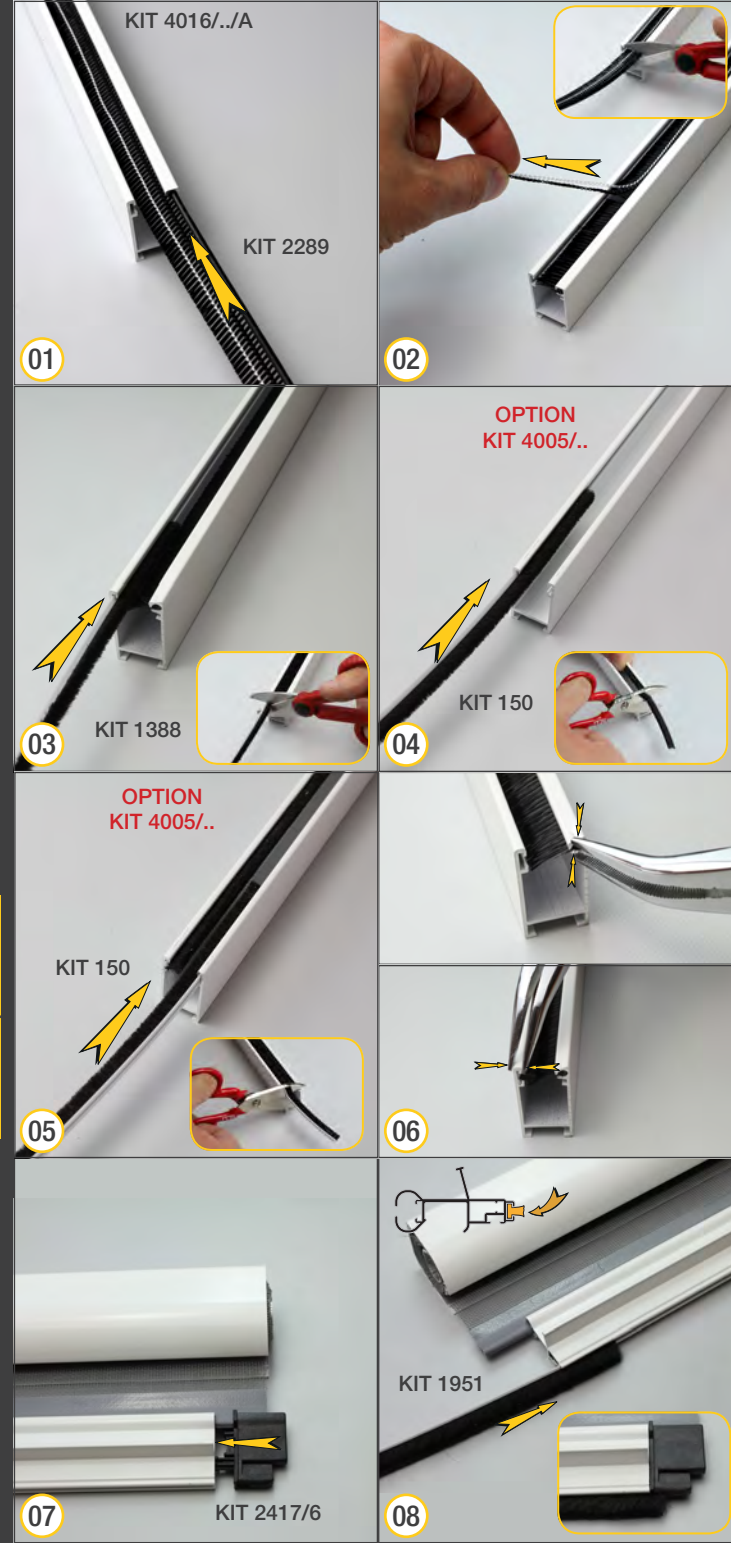

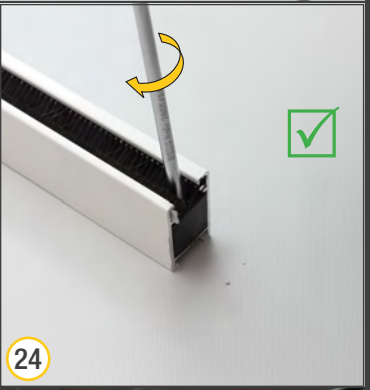
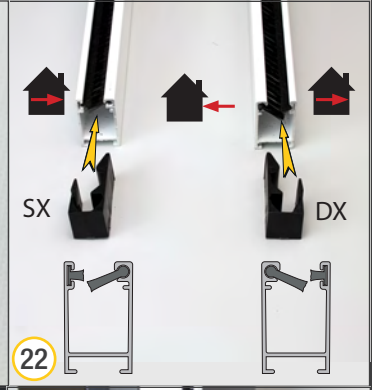
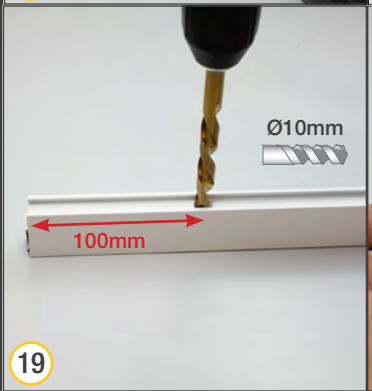
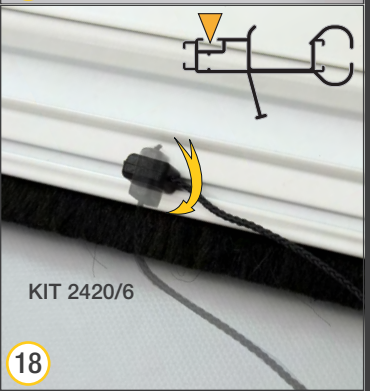
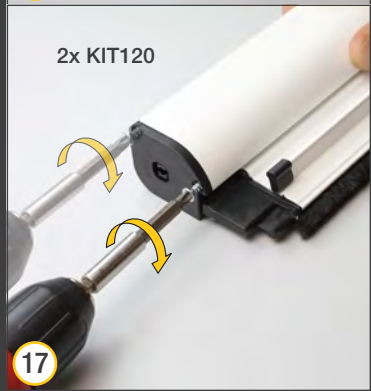
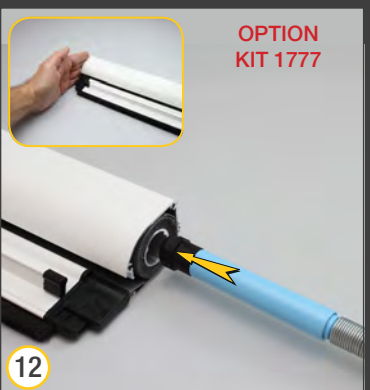
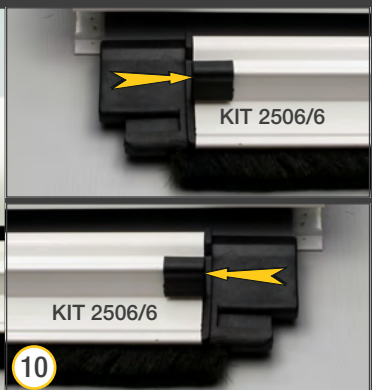
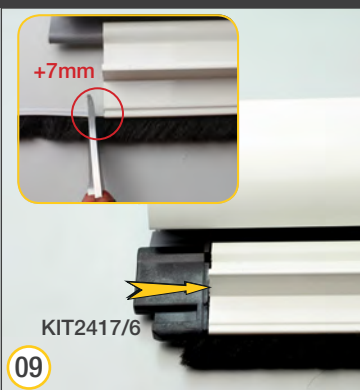

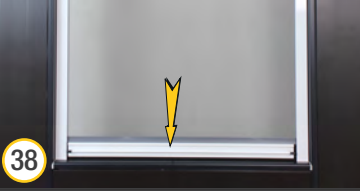
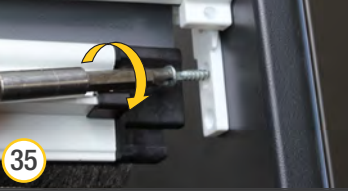
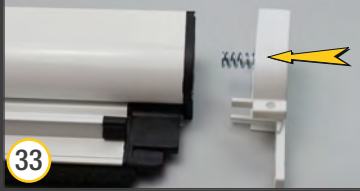
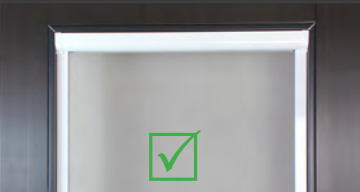

OPTION KIT 1823/..

OPTION KIT 1823/..

OPTION KIT 1823/..

OPTION KIT 1823/..

KIT 635

KIT 636

KIT 1823/..



UN BATTENTE
SINGLE DOOR
UN BATTANT
EIN FLÜGEL

ADRIATICO

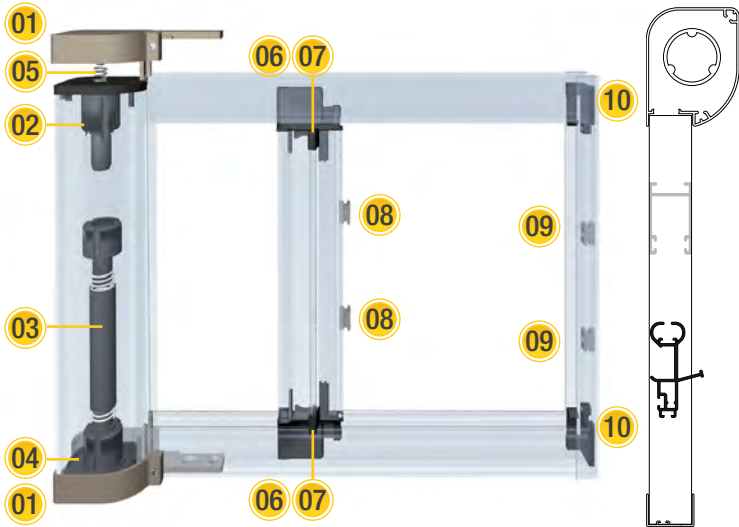

Accessori contenuti nel KIT 4032/... - Accessories contained in the KIT 4032/...
Accessoires contenus dans le KIT 4032/... - Im Bausatz enthaltenes Zubehör KIT 4032/...

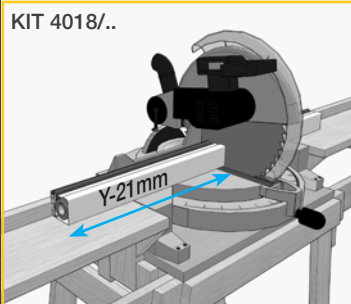
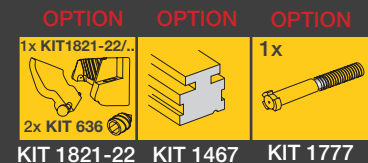
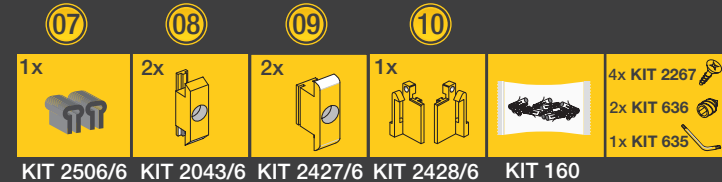

KIT 4018/..
Taglio cassone da misura foro
Cutting the cassette from wall to wall
Coupe caisson de la mesure du trou
Kastenzuschnitt von der Lichtmasse

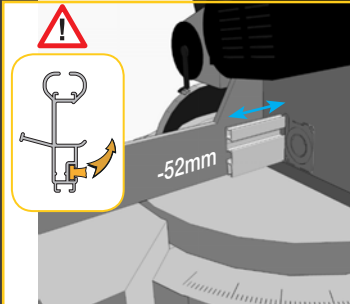

Taglio maniglia dopo taglio cassone
Cutting the handle after cutting the cassette
Couper barre poignée apres le coupe caisson
Griffzuschnitt nach der Kastenzuschnitt

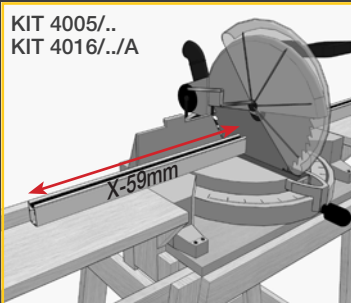

KIT 4005/..
KIT 4016/..A
Taglio guida da misura foro
Cutting the guide from wall to wall
Coupe coulisse de la mesure du trou
Führungszuschnitt von der Lichtmasse

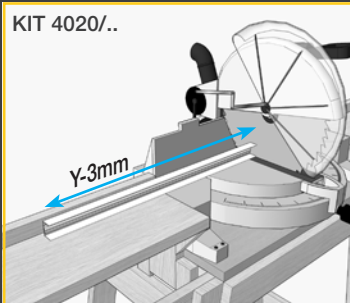

KIT 4020/..
Taglio profilo a U da misura foro
Cutting the U profile from wall to wall
Coupe profil en U de la mesure du trou
U.Profilzuschnitt von der Lichtmasse

Dimensioni senza frizione Dimensions without brake Dimensions sans frein Abmessungen ohne Bremse	
Dimensioni con frizione Dimensions with brake Dimensions avec frein Abmessungen mit Bremse	

Come rilevare le misure - How to take measurements - Comment prendre les mesures - Anleitung für Massen

Considerare solo la misura più piccola del foro architettonico.
Consider only the smallest measurement of the opening. Considérer la mesure plus petite.
Berücksichtigen das kleinste Maß.

Giri molla - Spring windings - Tours ressort - Federwindungen

KIT 2531	8	KIT4005/..
	9	KIT4016/..A
KIT 2540	20	KIT4005/..
	20	KIT4016/..A

Con frizione - with brake - avec frein - mit Bremse **KIT1777: +2**

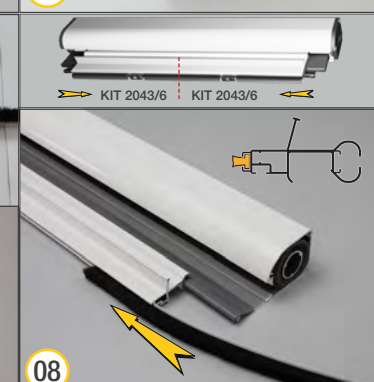
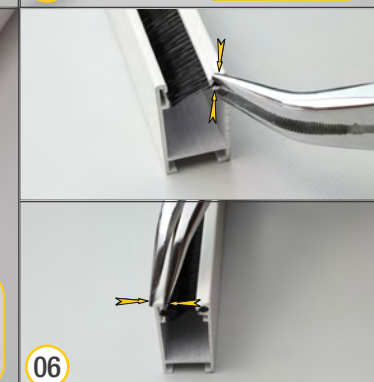
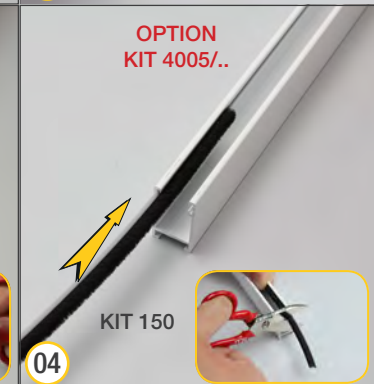
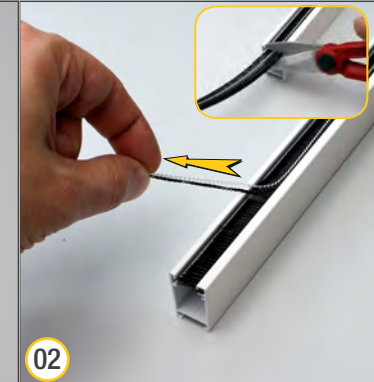
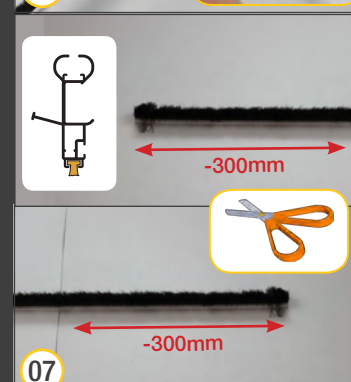
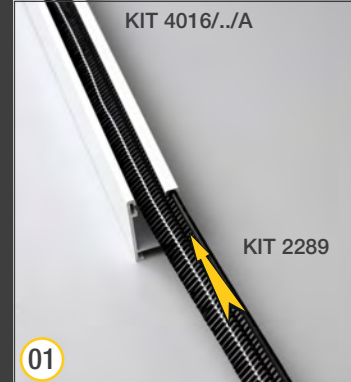

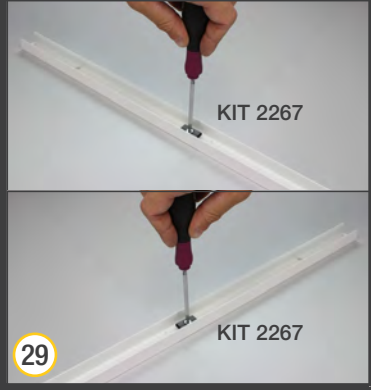
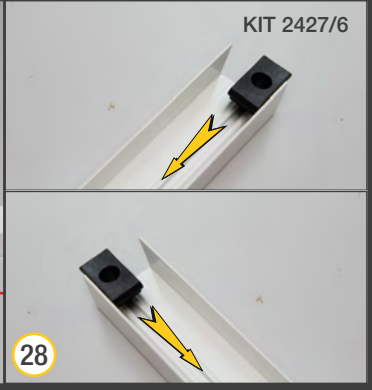
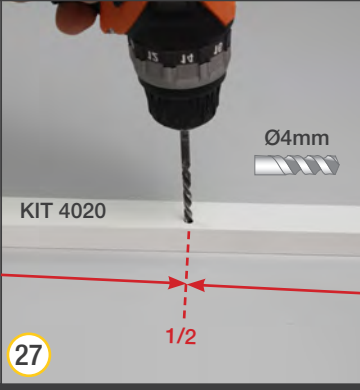
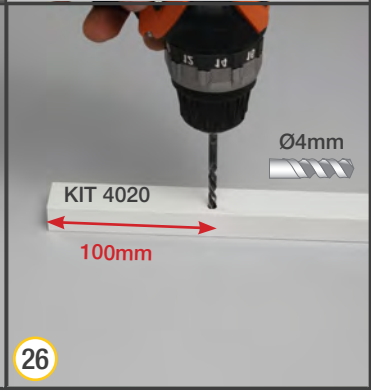
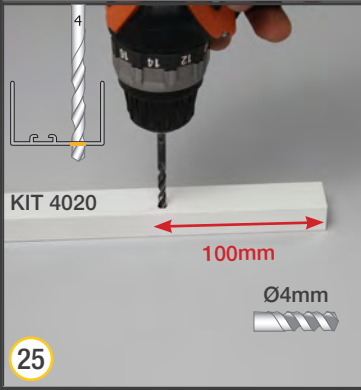
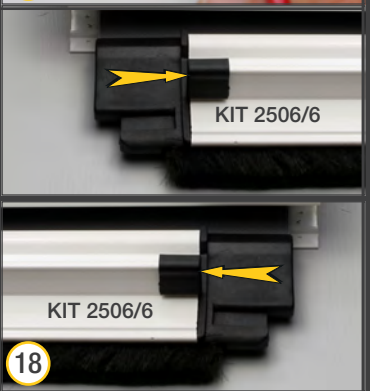
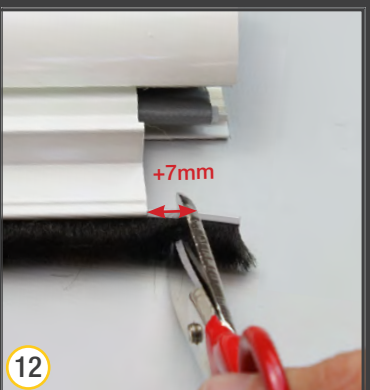
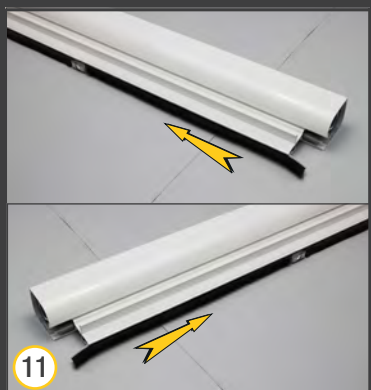

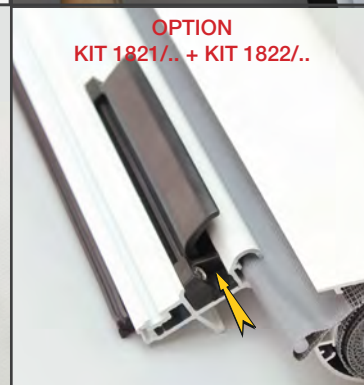
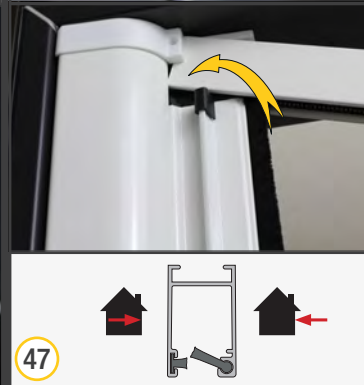
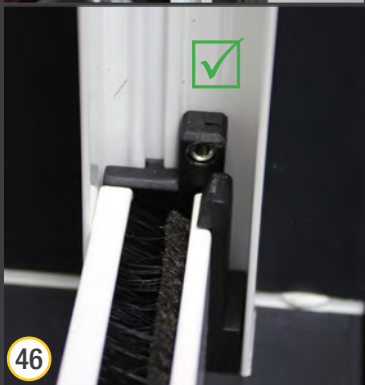
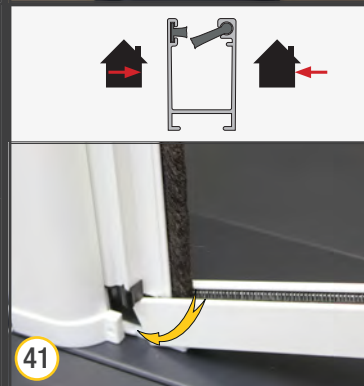
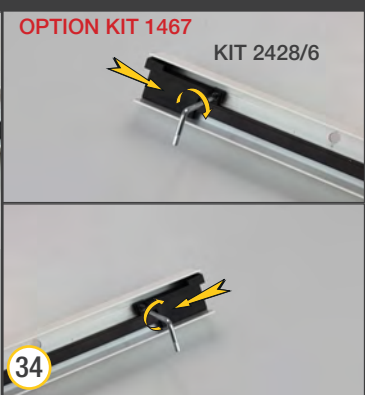

UN BATTENTE FRONTALE
SINGLE DOOR SURFACE MOUNT
UN BATTANT MONTAGE FRONTAL
EIN FLÜGEL FRONTALMONTAGE **ADRIATICO**

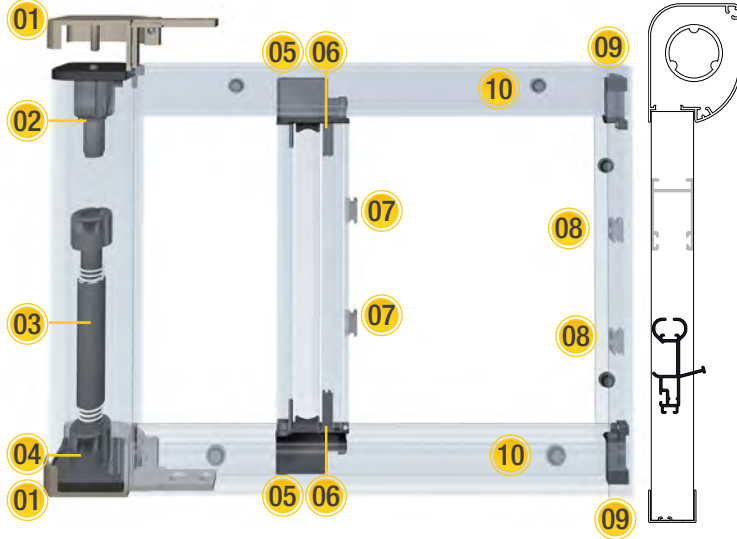

Accessori contenuti nel KIT 4032/... - Accessories contained in the KIT 4032/...
Accessoires contenus dans le KIT 4032/... - Im Bausatz enthaltenes Zubehör KIT 4032/...

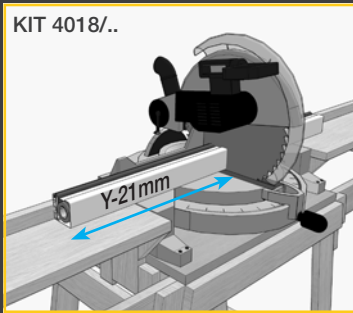
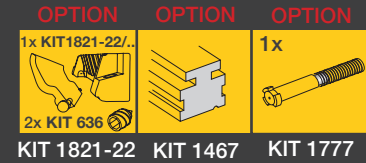
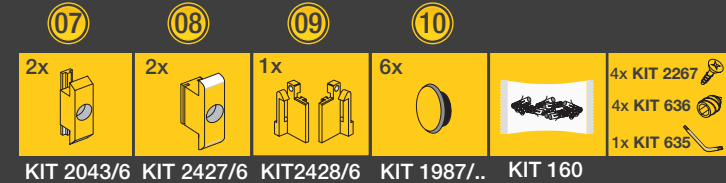

KIT 4018/..
Taglio cassone da misura foro
Cutting the cassette from wall to wall
Coupe caisson de la mesure du trou
Kastenzuschnitt von der Lichtmasse

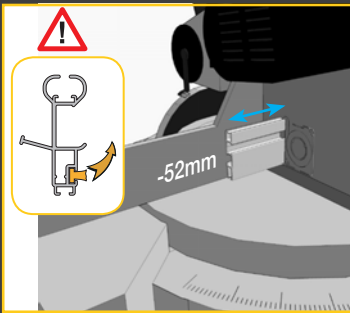

Taglio maniglia dopo taglio cassone
Cutting the handle after cutting the cassette
Couper barre poignée apres le coupe caisson
Griffzuschnitt nach der Kastenzuschnitt

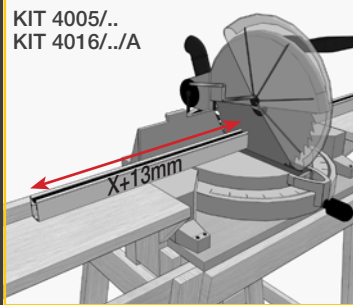

KIT 4005/..
KIT 4016/..A
Taglio guida da misura foro
Cutting the guide from wall to wall
Coupe coulisse de la mesure du trou
Führungszuschnitt von der Lichtmasse

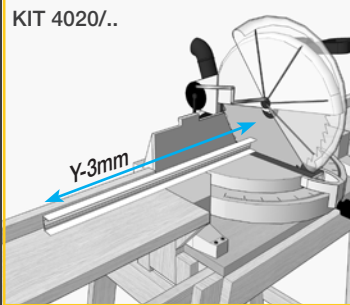

KIT 4020/..
Taglio profilo a U da misura foro
Cutting the U profile from wall to wall
Coupe profil en U de la mesure du trou
U.Profilzuschnitt von der Lichtmasse

Dimensioni senza frizione Dimensions without brake Dimensions sans frein Abmessungen ohne Bremse	
Dimensioni con frizione Dimensions with brake Dimensions avec frein Abmessungen mit Bremse	

Come rilevare le misure - How to take measurements - Comment prendre les mesures - Anleitung für Massen

Considerare solo la misura più piccola del foro architettonico.
Consider only the smallest measurement of the opening. Considérer la mesure plus petite. Berücksichtigen das kleinste Maß.

Giri molla - Spring windings - Tours ressort - Federwindungen

KIT 2531	8	KIT4005/..
	9	KIT4016/..A
KIT 2540	20	KIT4005/..
	20	KIT4016/..A

Con frizione - with brake - avec frein - mit Bremse **KIT1777: +2**

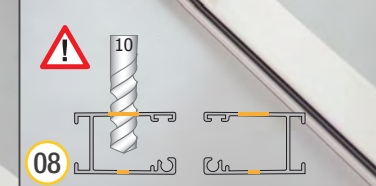
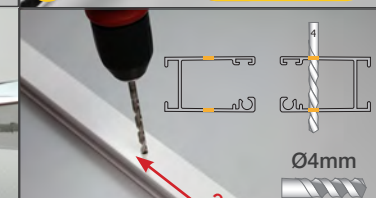
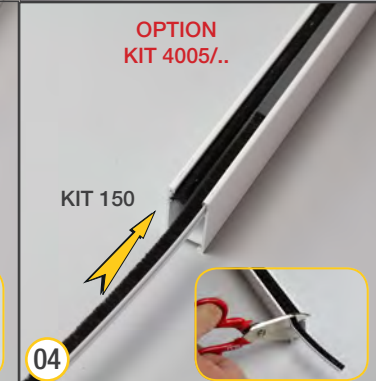
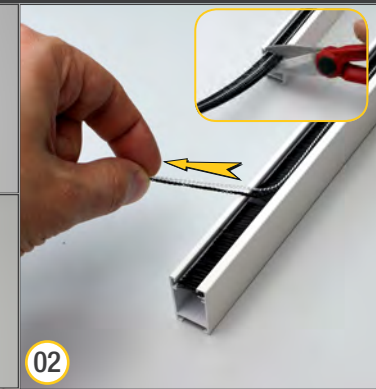
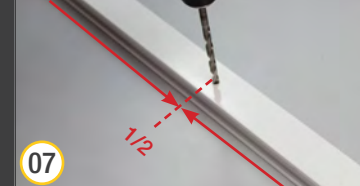
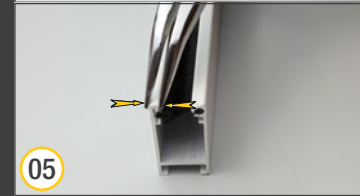
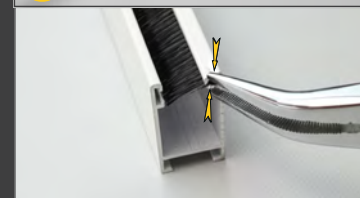
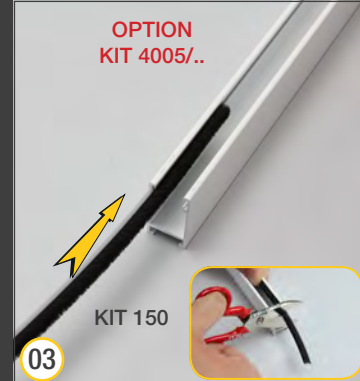

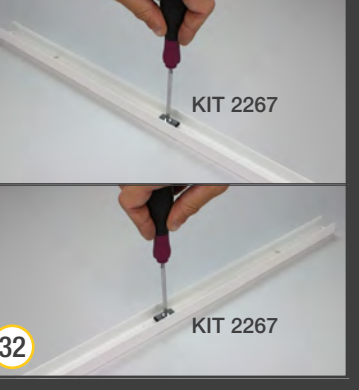
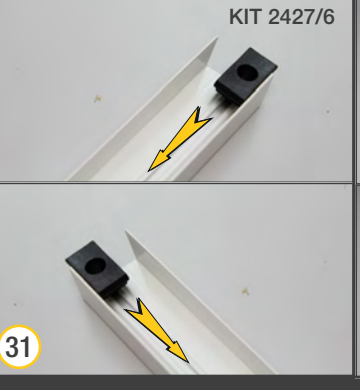
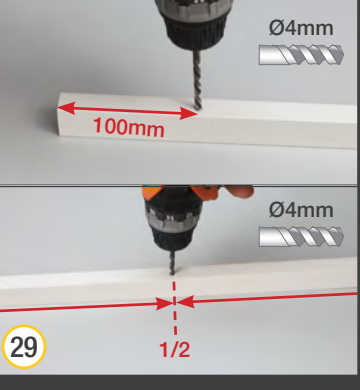
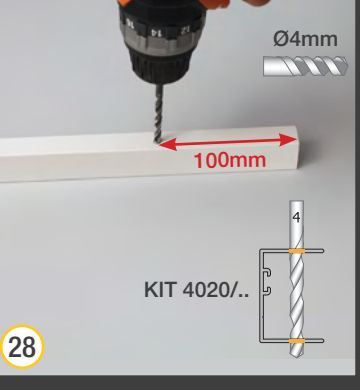
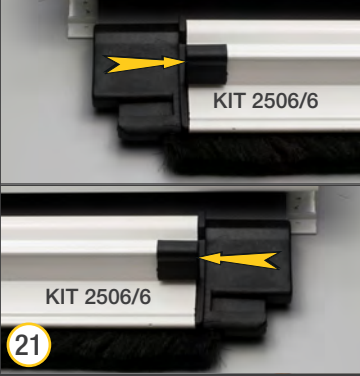
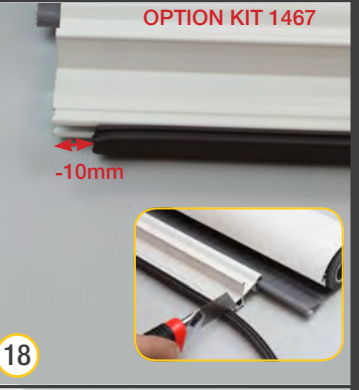
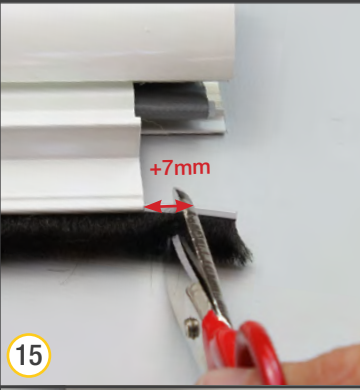
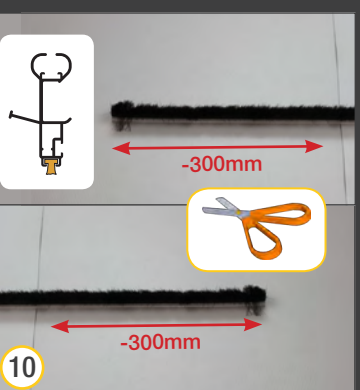
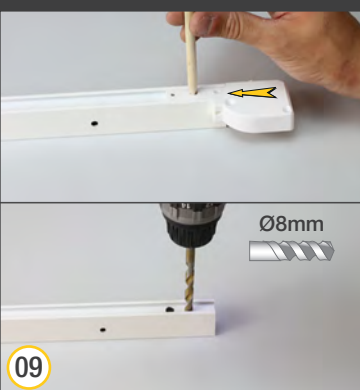

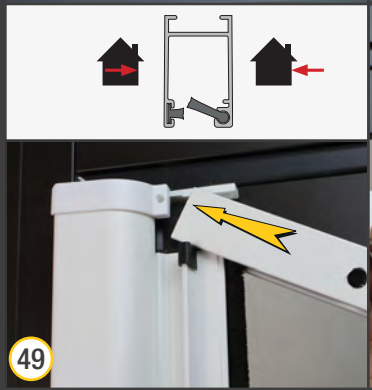
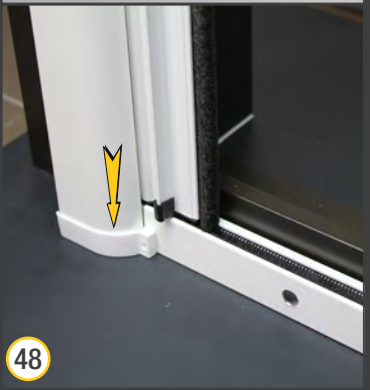
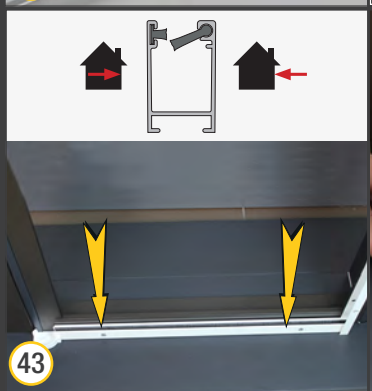
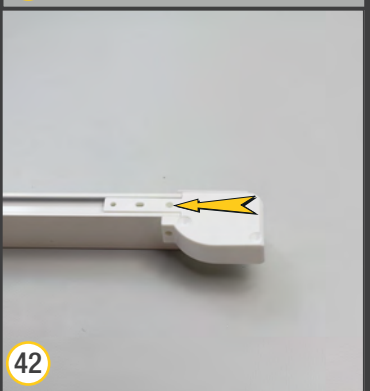
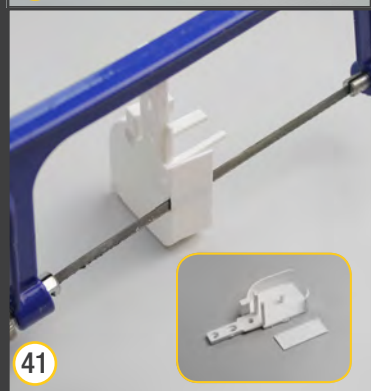
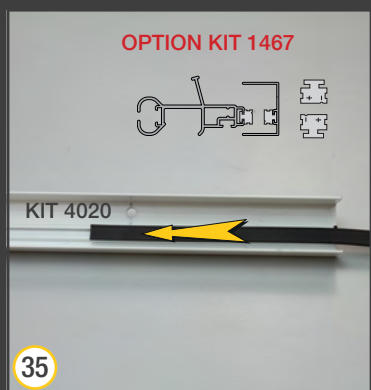
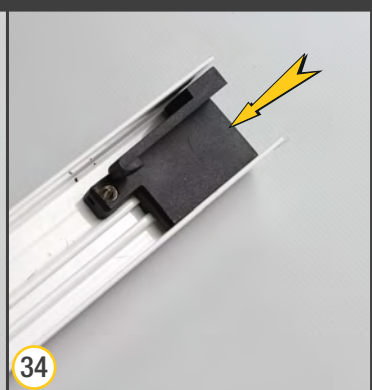

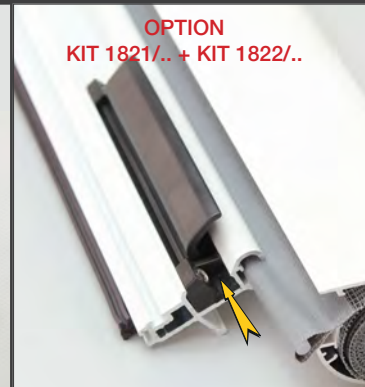
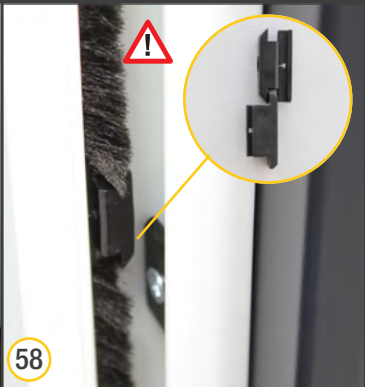

DICHIARAZIONE DI CONFORMITÀ

ai sensi della Direttiva Europea 98/37/CE all. II A e 2006/42/CE

La società Bettio Flyscreens S.r.l. di Bettio Denis & C. con sede in Via dell'Artigianato n°9, 30020 Marcon (Venezia), nella persona del Sig. Denis Bettio nella sua qualità di Legale Rappresentante espressamente delegato a questo scopo e sotto la sua propria esclusiva responsabilità,

DICHIARA

che la persona autorizzata a costituire il fascicolo tecnico, è l'Ing. Franco Zannoner reperibile presso l'Azienda; che la zanzariera con rete in fibra di vetro – Modello Adriatico – in varie misure come specificato nel catalogo in vigore,

È CONFORME

ai requisiti delle seguenti Direttive Europee:

- 98/37/CE del 22/06/98 (D.P.R. 459/96)
- 2006/42/CE
- EN 13561:2004 “tende da sole” requisiti di funzionamento e sicurezza. Resistenza al vento NPD.
- EN 14201:2004 Resistenza alle operazioni ripetute.
- EN 13120:2004 Tende tecniche - requisiti di funzionamento e sicurezza.
- UNI EN 349/94 Spazi minimi per evitare lo schiacciamento di parti del corpo.
- UNI EN ISO 12100-1/2005, UNI EN ISO 12100-2/2005 Sicurezza del macchinario. Principi generali di progettazione.
- UNI EN 1050/98 Principi per la valutazione del rischio.

nonchè alle loro modifiche e aggiornamenti ed alle disposizioni che ne attuano il recepimento all'interno dell'Ordinamento Legislativo Nazionale del paese di destinazione e di utilizzo della zanzariera / tenda.

Firma del delegato
Bettio Flyscreens S.r.l.
di Bettio Denis & C.
Denis Bettio

Marcon (VE),
29 dicembre 2009



DECLARATION OF CONFORMITY

in accordance with European Directive 98/37/EC annex II A and 2006/42/EC

The company Bettio Flyscreens S.r.l. di Bettio Denis & C. with registered office in Via dell'Artigianato No.9, 30020 Marcon (Venezia), as represented by Mr Denis Bettio in his capacity as Legal Representative expressly delegated for this purpose and under his own responsibility,

DECLARES

that the person authorized to create the technical file is the engineer Mr Franco Zannoner who can be contacted at the Company;
that the flyscreen with fibreglass mesh –Adriatico Model – in the various sizes as specified in the current Catalogue,

COMPLIES

with the requirements of the following European Directives:

- 98/37/CE of 22/06/98 (Italian Presidential Decree 459/96)
- 2006/42/EC
- EN 13561:2004 “External blinds” performance requirements including safety. Wind resistance NPD.
- EN 14201:2004 Resistance to repeated operations.
- EN 13120:2004 Internal blinds – performance requirements including safety.
- UNI EN 349/94 Minimum gaps to avoid crushing parts of the human body.
- UNI EN ISO 12100-1/2005, UNI EN ISO 12100-2/2005 Safety of machinery. General principles for design.
- UNI EN 1050/98 Principles for risk assessment.

It also complies with the amendments and updates of the above Directives and the provisions that implement their assimilation into the National Legal System of the country of destination and installation of the insect screen/blind.

Signature of person empowered
Bettio Flyscreens S.r.l.
di Bettio Denis & C.
Denis Bettio

Marcon (VE),
December 29, 2009



DECLARATION DE CONFORMITE

conformément à la Directive Européenne 98/37/CE annexe II A et 2006/42/CE

La société Bettio Flyscreens S.r.l. de Bettio Denis & C. située Via dell'Artigianato n°9, 30020 Marcon (Venise), en la personne de M. Denis Bettio, en qualité de Représentant Légal expressément délégué pour ce faire et sous sa propre et unique responsabilité,

DÉCLARE

que la personne autorisée à constituer le fascicule technique est l'ingénieur Franco Zannoner travaillant dans l'Entreprise, que la moustiquaire à toile en fibre de verre - Modèle Adriatico - en diverses dimensions comme indiqué dans le Catalogue "Adriatico" en vigueur,

EST CONFORME

aux exigences requises par les Directives Européennes suivantes:

- 98/37/CE du 22/06/98 (D.P.R. 459/96)
- 2006/42/CE
- EN 13561:2004 "stores pare-soleil" exigences de fonctionnement et de sûreté. Résistance au vent NPD.
- EN 14201:2004 Résistance aux opérations répétées.
- EN 13120:2004 Rideaux techniques - exigences de fonctionnement et de sûreté.
- UNI EN 349/94 Espaces minimum pour éviter l'écrasement de parties du corps.
- UNI EN ISO 12100-1/2005, UNI EN ISO 12100-2/2005 Sécurité de la machinerie. Principes généraux de conception.
- UNI EN 1050/98 Principes pour l'évaluation du risque.

Ainsi qu'à leurs modifications et révisions et aux dispositions qui en effectuent la transposition à l'intérieur de l'Organisation Législative Nationale du pays auquel est destiné la moustiquaire/le rideau.

Signature du délégué
Bettio Flyscreens S.r.l.
di Bettio Denis & C.
Denis Bettio

Marcon (VE),
29 décembre 2009



KONFORMITÄTSERKLÄRUNG

gemäß der Europäischen Richtlinie 98/37/EG Anl. II A und 2006/42/EG

Die Firma Bettio Flyscreens S.r.l. di Bettio Denis & C. mit Sitz in Via dell'Artigianato 9, 30020 Marcon (Venedig),

ERKLÄRT

vertreten durch Herrn Denis Bettio in seiner Eigenschaft als ausdrücklich für diesen Zweck bevollmächtigter gesetzlicher Vertreter und unter der eigenen ausschließlichen Verantwortung, dass die für die Erstellung der technischen Unterlagen zugelassene Person der im Unternehmen erreichbare Ing. Franco Zannoner ist; dass das Fliegengitter mit Glasfasernetz - Modell Adriatico - in verschiedenen Größen wie nach gültigem Katalog mit den Anforderungen der folgenden Europäischen Richtlinien

ÜBEREINSTIMMT:

- 98/37/EG vom 22.06.98 (ital. Dekret des Präsidenten der Republik 459/96)
- 2006/42/EG
- EN 13561:2004 "Markisen" Leistungs- und Sicherheitsanforderungen. Windfestigkeit NPD.
- EN 14201:2004 Widerstand gegen wiederholte Bedienungen.
- EN 13120:2004 Abschlüsse innen - Leistungs- und Sicherheitsanforderungen.
- UNI EN 349/94 Mindestabstand zur Vermeidung von Quetschungen von Körperteilen.
- UNI EN ISO 12100-1/2005, UNI EN ISO 12100-2/2005 Sicherheit von Maschinen. Allgemeine Gestaltungsleitsätze.
- UNI EN 1050/98 Leitsätze zur Risikobeurteilung.

und mit ihren Änderungen und Aktualisierungen sowie den Bestimmungen, die ihre Umsetzung in der nationalen Rechtsordnung des Bestimmungs- und Benutzungslands des Fliegengitters / der Markise vollziehen.

Unterschrift des Bevollmächtigten
Bettio Flyscreens S.r.l.
di Bettio Denis & C.
Denis Bettio

Marcon (VE),
29. Dezember 2009



ISTRUZIONI D'USO E MANUTENZIONE (ISTRUZIONI ORIGINALI)

1. SCOPO

Queste istruzioni sono rivolte a chi utilizza la zanzariera come installatore, manutentore, proprietario o utente. Con questo strumento la **Bettio Flyscreens S.r.l.** intende fornire al Cliente uno strumento di supporto per un uso più consapevole e corretto delle zanzariere, al fine di ottimizzare le loro prestazioni ed evitare incidenti nel corso delle attività di installazione e di utilizzo.

E' quindi consigliato, per un corretto e vantaggioso utilizzo del sistema, tenere disponibili le presenti note ai fini di garantire una rapida consultazione ogni qualvolta le circostanze lo rendano necessario. Esse sono supportate dal Manuale d'Uso e Manutenzione e dal Fascicolo Tecnico disponibili in Azienda.

2. CAMPO DI APPLICAZIONE

Il presente manuale di istruzioni si riferisce al modello **Adriatico** per il quale sono coerentemente adattati i contenuti.

3. RIFERIMENTI

Le presenti istruzioni, sono state redatte, secondo il punto 1.7.4 della Direttiva 2006/42/CE e tenendo conto delle normali condizioni di uso della zanzariera al fine di informare, unitamente alle altre istruzioni per l'uso reperibili nel contenitore degli accessori, i montatori e gli utilizzatori anche sui rischi residui che la stessa presenta.

4. USI PREVISTI

La funzione del sistema installato è esclusivamente quella di dare protezione contro l'intrusione di insetti e piccoli animali negli ambienti da proteggere.

Ogni impiego diverso da quello indicato deve essere considerato improprio, e pertanto vietato, in quanto le relative condizioni di esercizio non sono state considerate nell'analisi dei rischi condotta dal fabbricante e per il quale potrebbero non essere presenti protezioni specifiche. E' vietato appoggiarsi alla rete. E' vietato lasciare la barra maniglia senza accompagnarla fino al totale riavvolgimento della rete.

L'uso improprio assolve da ogni responsabilità il costruttore stesso, per eventuali danni causati a persone o cose. Il mancato rispetto delle condizioni d'uso fa decadere automaticamente qualsiasi tipo di garanzia data dal produttore.

5. REQUISITI DELL'UTILIZZATORE

L'uso normale della zanzariera, è consentito ad utilizzatori non professionisti purché di età superiore ad anni 12.

Le operazioni di installazione, riparazione e manutenzione, devono essere effettuate da persone in possesso di competenze tecnico-pratiche sufficienti per utilizzare le attrezzature anche elettriche necessarie, con la sicurezza indispensabile ad evitare incidenti.

6. RACCOMANDAZIONI PER L'INSTALLAZIONE

L'installazione deve essere eseguita nel pieno rispetto del D.Lgs. 81/2008 e delle successive modifiche e integrazioni, per tutto ciò che attiene la sicurezza delle persone.

L'installatore è responsabile ai sensi della legge vigente, per tutto ciò che riguarda la Sicurezza del prodotto installato.

E' necessario controllare, prima dell'utilizzo che gli attrezzi, (trapani, avvitatori, trabattelli, ponteggi, scale e tutti i dispositivi di protezione individuale imbracature, cinghie di sicurezza, guanti, scarpe di sicurezza, elmetti, ecc.), eventualmente utilizzati, siano a norma ed in buono stato. Nel caso gli installatori siano più di uno, è necessario coordinare i lavori, definire i compiti e le responsabilità.

Gli installatori devono comportarsi in conformità alle istruzioni di sicurezza ricevute e applicabili. Nel caso in cui la zanzariera debba essere montata ad un piano elevato rispetto a quello di terra, è necessario delimitare e presidiare l'area durante la salita al piano della zanzariera in modo che nessuno possa trovarsi sotto l'eventuale carico sospeso.

7. INSTALLAZIONE DELLA STRUTTURA MECCANICA

Un'installazione non corretta può essere causa di infortuni alle persone. Leggere attentamente le istruzioni per un fissaggio corretto della zanzariera in modo da evitare rischi di caduta della stessa.

E' necessario verificare lo stato del muro sul quale viene effettuato l'ancoraggio in base allo sforzo dinamico che la zanzariera eserciterà in funzione della velocità del vento di 50 km/h rispondente alla classe di resistenza descritta dalla UNI EN 13561 e determinata in riferimento alla EN 1932. La scelta dei tasselli di ancoraggio è dipendente dal tipo e dallo stato del muro. Si consiglia di usare tasselli espansibili in materiale plastico tipo fischer con viti da 4X40 mm, contenute nell'inclusa confezione. In presenza di mattoni forati utilizzare tasselli espansibili con collante chimico di adeguate dimensioni.

Nel caso non siano rispettati i requisiti di resistenza necessari a un fissaggio in sicurezza, aumentare il numero di tasselli.

FARE ATTENZIONE NELLA MANIPOLAZIONE DELLA ZANZARIERA: GLI AVVOLGITORI SONO MONTATI CON MOLLE CARICHE.

Le istruzioni di preparazione e posa in opera, sono descritte nell'allegato foglio contenuto nell'incluso contenitore degli accessori.

L'eventuale attività di sigillatura sarà eseguita con resina silconica neutra.

Quando la velocità del vento raggiunge i 20 km/h è necessario chiudere le zanzariere.

8. MANUTENZIONE

ATTENZIONE: tutte le operazioni di manutenzione vanno effettuate in sicurezza utilizzando adeguate attrezzature marchiate CE.

8.1 Manutenzione ordinaria

Data l'alta qualità dei materiali impiegati nella costruzione della zanzariera, non è prevista alcuna manutenzione ordinaria tranne l'eventuale pulizia del telo per salvaguardarlo dalla formazione di muffe causate dal deposito di polveri o altro materiale sulla rete.

La rete, deve essere controllata visivamente almeno 2 volte all'anno; in primavera prima dell'utilizzo per la stagione estiva ed in autunno prima della chiusura invernale.

La pulizia della rete può essere effettuata con aspirazione della polvere o con spugna o panno umido utilizzando acqua tiepida. Fare

asciugare la rete dopo la pulizia e prima dell'avvolgimento. Per la pulizia, NON utilizzare solventi-ammoniaca-idrocarburi.

ATTENZIONE: la pulizia eseguita con l'utilizzo di scale, trabattelli o altro è riservata a personale in possesso di adeguata competenza che dovrà eseguire le operazioni nel rispetto delle norme di sicurezza e dovrà utilizzare gli adeguati dispositivi di protezione individuale ed eventualmente anche imbracature di sicurezza con fune di trattenuta (vedi D.Lgs. 81/2008)

8.2 Manutenzione straordinaria

ATTENZIONE: Per l'eventuale smontaggio della zanzariera o di parti di essa, fare riferimento alle Istruzioni allegate. In presenza di strappi sulla rete anche di piccole dimensioni, è necessario provvedere alla loro sostituzione.

In caso di necessità, usare parti di ricambio originali pena la decadenza della garanzia.

9. GARANZIA

La garanzia si applica in relazione ai contenuti del D. Lgs. n. 24 del 02.02.2002. La durata della Garanzia è di 24 mesi (o maggiore quando esplicitamente indicato) per le Persone fisiche che acquistano il prodotto per scopi che possono considerarsi estranei alla loro attività professionale (Cliente privato finale). E' di 12 mesi se il prodotto è fatturato a un'Impresa o Professione soggetto di IVA.

Poiché è prassi utilizzare il documento fiscale di vendita per dare validità e data certa alla garanzia, lo stesso documento ne determinerà la durata.

9.1 Norme per la validità della Garanzia

- Rispettare l'uso consentito del prodotto.

- Rispettare le istruzioni di montaggio e le norme d'uso e manutenzione.

- Usare le parti di ricambio originali Bettio Flyscreens S.r.l.

- La garanzia sarà valida solo se accompagnata dal documento di vendita, comprovante la data d'acquisto.

9.2 Decadimento della Garanzia.

- Uso improprio del prodotto in occasione di vento, pioggia, grandine, neve e/o altri eventi combinati.

- Cedimento della parte muraria dove il prodotto è stato ancorato.

- Manomissione del prodotto; installazione, smontaggio, manutenzione non effettuati secondo le norme e le presenti istruzioni.

- Uso di parti di ricambio non originali Bettio Flyscreens S.r.l.

- Rimozione od occultamento dell'etichetta identificativa Bettio Flyscreens S.r.l., per cui la rintracciabilità del prodotto non risulta possibile.

Per altre specifiche esclusioni dalla Garanzia, si fa riferimento alle eventuali note specificate dall'Azienda.

Per qualsiasi controversia, si elegge quale unico foro competente quello di Venezia.

10. IMBALLO MOVIMENTAZIONE E TRASPORTO

La zanzariera è imballata con involucro di polietilene e con sagome di cartone per proteggere e bloccare i componenti durante il trasporto.

Date le dimensioni e la forma del prodotto, è necessario, oltre la misura in lunghezza di 240cm, effettuare la movimentazione manuale in due persone. L'imballo contiene le istruzioni di montaggio, d'uso e manutenzione

Non lasciare alla portata dei bambini i materiali d'imballo, possono costituire fonte di pericolo per gli stessi.

11. ELENCO DEI RISCHI

11.1 Installazione: Adottare tutte le precauzioni previste con particolare riguardo a quelle riguardanti i rischi di caduta.

11.2 Rischi inerenti l'utilizzo e la normale manutenzione:

Zanzariere con molla di richiamo:

a) Versione finestra / porta con scorrimento verticale ↓ : velocità di riavvolgimento con pericolo di urto con la barra maniglia;

b) Versione a finestra / porta con scorrimento verticale ↓ : velocità di riavvolgimento con pericolo di urto con il nappino;

c) Versione laterale 1 battente → o 2 battenti →← : velocità di riavvolgimento con pericolo di urto con la barra maniglia;

d) Pericolo di sgancio incontrollato e ambiguità di funzionamento: velocità di riavvolgimento con pericolo di urto con la barra maniglia;

e) Pericolo di caduta durante le operazioni di pulizia della rete: evitare di sporgersi dalle finestre, utilizzando attrezzature adeguate.

11.3 Rischi inerenti la manutenzione/riparazione:

a) Pericolo di urto durante le operazioni di carico/scarico della molla;

b) Pericolo di non corretto ripristino della zanzariera durante il cambio della rete;

c) Pericolo derivante dal mancato utilizzo di attrezzature e DPI non marchiati CE.

11.4 Pericolo di inciampo sulla guida della porta con apertura laterale

11.5 Rischi inerenti la dismissione: la dismissione del prodotto deve essere eseguita in base alle norme al momento in vigore.

INSTRUCTIONS FOR USE AND MAINTENANCE (TRANSLATION OF ORIGINAL INSTRUCTIONS)

1. PURPOSE

These instructions are intended for those who use the flyscreen, such as the installer, maintenance person, owner or user.

With this instruction booklet **Bettio Flyscreens S.r.l.** wishes to provide Customers with a tool for better, correct use of the flyscreens so as to optimize their performance and avoid accidents during installation and use.

For correct and best use of the system it is therefore recommended that these notes be kept to hand for quick reference whenever required. Supplementary information may be had in the Operating and Maintenance Guide and the Technical File available at the Company's offices.

2. SCOPE

This instruction booklet refers specifically to the **Adriatico** model.

3. REFERENCES

These instructions have been prepared, as have other instructions for use accompanying the accessories, in accordance with point 1.7.4 of Directive 2006/42/EEC taking into consideration normal conditions of use of the flyscreen, to inform installers and users also of the residual risks that the product presents.

4. ENVISAGED USE

The function of the installed system is solely to provide protection against the intrusion of insects and small animals into the environments to be protected.

Any use other than has been described above is considered incorrect and is therefore forbidden, since the relative working conditions will not have been taken into account when the manufacturer analysed the risks and consequently there could be no specific protective devices fitted. Do not lean against the mesh. Do not let go of the handle rail until the mesh screen is fully rewound.

Misuse relieves the manufacturer from all liability for any injury to persons or damage to property. Failure to comply with the conditions of use automatically invalidates any type of warranty given by the manufacturer.

5. USER REQUIREMENTS

Normal use of the flyscreen is allowed for non-professional users provided they are aged 12 and over.

Installation, repair and maintenance must be carried out by persons with sufficient technical-practical skills to use the necessary equipment, also electrical, in all safety.

6. RECOMMENDATIONS FOR INSTALLATION

Installation must be carried out in full compliance with Italian Legislative Decree 81/2008 and subsequent amendments and additions for all that concerns the safety of persons.

In accordance with current laws, the installer is responsible for everything that regards the safety of the installed product.

Before using any tools (drills, screwdrivers, work platforms, scaffolding, steps and all personal protection equipment, slings/harness, safety belts, gloves, safety shoes, helmets, etc.), check that they are in compliance with regulations and in good condition.

If there is more than one installer, the work must be coordinated and the tasks and responsibilities defined.

The installer must abide by the applicable safety instructions received. If the flyscreen is to be installed on any floor above ground level, the area must be cordoned off and supervised while the flyscreen is being raised to the relevant floor so that no person is under any suspended load.

7. INSTALLATION OF THE MECHANICAL STRUCTURE

Incorrect installation can cause injury to persons. Carefully read the instructions for correct fixing of the flyscreen so that there is no risk of it falling down.

The state of the wall on which the flyscreen will be fixed must be checked on the basis of the dynamic stress that the flyscreen will exert in relation to a wind speed of 50 km/h, which corresponds to the wind resistance class described in UNI EN 13561 and calculated with reference to EN 1932.

The fixings or anchors depend on the type and state of the wall. It is advisable to use Fischer type plastic expansion plugs with 4X40 mm screws, which are contained in the kit. With hollow bricks use suitably sized expansion plugs with chemical adhesive.

If the resistance requirements necessary for safe fixing are not satisfied, increase the number of wall plugs.

TAKE CARE WHEN HANDLING THE FLYSCREEN: THE WINDER MECHANISMS ARE MOUNTED WITH LOADED SPRINGS.

The instructions for preparation and installation are described on the sheet contained in the enclosed accessories box.

Any sealing must be done with neutral silicone resin.

The flyscreens must be closed when the wind speed reaches 20 km/h.

8.MAINTENANCE

CAUTION: all maintenance work must be carried out in all safety using suitable CE-marked equipment.

8.1 Routine maintenance

Given the high quality of the materials used in making the flyscreen, no routine maintenance is envisaged other than cleaning the blind to protect it against the formation of mould/mildew caused by dust or other material being deposited on the mesh.

The mesh must be visually inspected at least twice a year; in spring before being used for the summer and in autumn before packing it up for the winter. The mesh may be cleaned with a vacuum cleaner or with a sponge or cloth dampened with lukewarm water. Let the mesh dry thoroughly after cleaning before winding it up. Do NOT use solvents, ammonia or hydrocarbons for cleaning.

CAUTION: cleaning carried out using steps, platforms or such must only be done by suitably experienced personnel working in conformity with safety regulations and who must use suitable personal protective equipment and if necessary also body harnesses

with separate safety line (see Italian Legislative Decrees 81/2008)

8.2 Extraordinary maintenance

CAUTION: If the flyscreen or any part of it needs to be dismantled, see the enclosed instructions. If the mesh is torn, however small the tear, the mesh must be replaced.

If replacement is necessary, only use original spare parts otherwise the warranty is invalidated.

9. WARRANTY

The warranty is applicable in relation to the contents of Italian Legislative Decree No. 24 of 02.02.2002. The Warranty is for 24 months (or more when explicitly indicated) and covers natural persons who purchase the product for purposes that may be considered unrelated to their professional activity (private end customer).

The warranty is for 12 months if the product is invoiced to a Company or Professional office subject to VAT.

As is accepted practice, the original invoice or receipt is evidence of the date of purchase and therefore of the validity and duration of the warranty.

9.1 Rules for the Warranty to be valid

- Comply with the allowed use of the product.

- Comply with the installation instructions and the instructions for use and maintenance.

- Use Bettio Flyscreens S.r.l. original spare parts

- The warranty will only be valid if accompanied by the invoice or receipt giving evidence of the date of purchase.

9.2 Invalidation of the Warranty

- Misuse of the product in the presence of wind, rain, hail, snow or other combined events.

- Collapse of the masonry where the product has been anchored.

- Tampering with the product; installation, dismantling and maintenance not carried out in accordance with regulations or these instructions.

- Use of other than Bettio Flyscreens S.r.l. original spare parts.

- Removal or concealment of the Bettio Flyscreens S.r.l. identification label making traceability of the product impossible.

For other specific exclusions from the Warranty, see any notes specified by the Company.

For all and any dispute the sole place of jurisdiction is Venice.

10. PACKAGING, HANDLING AND TRANSPORTATION

The flyscreen is packed in protective polyethylene wrapping and wedged with cardboard shapes to prevent the components from moving during transportation. Given the size and shape of the product, when it is longer than 240 cm it must be handled by two persons.

The packaging contains the instructions for installation, use and maintenance.

Keep the packaging materials out of reach of children, since they can be a source of danger.

11. LIST OF RISKS

11.1 Installation: take all the necessary precautions especially in respect of the risks of fall.

11.2 Risks related to use and routine maintenance:

Flyscreens with return spring:

a) Vertical sliding window/door version ↓ : winding speed with danger of impact with the handle rail;

b) Vertical sliding window/door version ↓ : winding speed with danger of impact with the tassel;

c) 1 leaf → or 2 leaf horizontal sliding version →← : winding speed with danger of impact with the handle rail;

d) Danger of uncontrolled release and operating difficulties: winding speed with danger of impact with the handle rail;

e) Danger of fall during cleaning of mesh: avoid leaning out of windows, use suitable equipment.

11.3 Risks related to maintenance/repair:

a) Danger of impact during spring loading/release operations;

b) Danger of incorrect refitting of the flyscreen after mesh replacement;

c) Danger due to failure to use equipment and to PPE that does not bear the EC mark.

11.4 Danger of tripping over guide for door with side opening

11.5 Risks related to disposal: the product must be disposed of in accordance with rules and regulations currently in force.

NOTICE D'UTILISATION ET DE MAINTENANCE (TRADUCTION DES INSTRUCTIONS D'ORIGINE)

1. BUT

Cette notice s'adresse à tous ceux qui utiliseront la moustiquaire en tant qu'installateur, responsable de l'entretien, propriétaire ou utilisateur. L'objectif de la **Bettio Flyscreens S.r.l.** est de fournir au Client un instrument de support lui permettant d'utiliser les moustiquaires de façon plus appropriée afin d'en optimiser les prestations et d'éviter les incidents liés à leur installation et utilisation.

Pour bien utiliser et exploiter l'équipement, il est donc conseillé de conserver cette notice à portée de la main de manière à pouvoir la consulter rapidement chaque fois que cela est nécessaire. Pour toute information complémentaire, l'Entreprise met à disposition un Mode d'Emploi et de Maintenance ainsi qu'un Fascicule Technique.

2. DOMAINE D'APPLICATION

Le contenu de cette notice se réfère spécifiquement au modèle **Adriatico**.

3. REFERENCES

Cette notice a été rédigée selon le point 1.7.4 de la Directive 2006/42/CEE, en tenant compte de conditions normales d'utilisation de la moustiquaire afin d'informer, au même titre que les autres instructions incluses dans la boîte des accessoires, les monteurs et les utilisateurs des risques résiduels que celle-ci pourrait présenter.

4. USAGES PREVUS

Le système installé a uniquement pour fonction de protéger les pièces qui en sont équipées de l'intrusion des insectes et des petits animaux. Toute utilisation différente de celle indiquée doit être considérée impropre, et donc interdite, dans la mesure où l'analyse des risques effectuée par le fabricant n'a pas pris en compte ces autres conditions de fonctionnement qui pourraient donc ne pas présenter de protections appropriées. Il est interdit de s'appuyer contre la toile. Il est interdit de lacher la barre-poignée avant d'avoir totalement réenroulé la toile sur le rouleau. Un usage impropre dégage le constructeur de toute responsabilité dans le cas d'éventuels dommages provoqués aux personnes ou aux choses. Toute garantie donnée par le producteur déchoit automatiquement en cas de non-respect des conditions d'utilisation.

5. CARACTERISTIQUES DE L'UTILISATEUR

L'utilisation normale de la moustiquaire est consentie à toute personne de plus de 12 ans.

Les opérations d'installation, réparation et maintenance, doivent être effectuées par des personnes dotées des compétences techniques et pratiques suffisantes pour utiliser en toute sécurité les équipements nécessaires, même s'ils sont électriques.

6. RECOMMANDATIONS CONCERNANT L'INSTALLATION

L'installation doit être effectuée dans le respect total du D.Lgs. 81/2008 ainsi que de ses modifications et intégrations successives, pour tout ce qui concerne la sécurité des personnes. L'installateur est responsable conformément à la loi en vigueur pour tout ce qui concerne la sécurité du produit installé. Il est nécessaire de contrôler que les outils (perceuses, visseuses, échafaudages, passerelles, échelles ainsi que tous les dispositifs de protection individuelle comme les harnais, les courroies de sécurité, les gants, les chaussures de sécurité, les casques, etc.), éventuellement utilisés, sont aux normes et en bon état. Si l'installation est effectuée par plusieurs personnes, il est nécessaire de coordonner les travaux et de définir les tâches et les responsabilités de chacune d'elles.

Les installateurs doivent se comporter conformément aux consignes de sécurité reçues et applicables. Si la moustiquaire doit être montée à un étage élevé, la zone doit être délimitée et protégée au sol, pendant toute la montée de la moustiquaire à l'étage, de manière à ce que personne ne puisse se trouver sous la charge suspendue.

7. INSTALLATION DE LA STRUCTURE MECANIQUE

Une mauvaise installation peut provoquer des accidents. Lire attentivement les instructions concernant la fixation de la moustiquaire pour éviter tout risque de chute de cette dernière.

Il est nécessaire de contrôler l'état du mur sur lequel l'ancrage doit être effectué en tenant compte de l'effort dynamique que la moustiquaire exercera en fonction d'une vitesse du vent de 50 km/h correspondant à la classe de résistance décrite par la UNI EN 13561 et déterminée en référence à la EN 1932. Le choix des chevilles d'ancrage dépend du type de mur et de l'état dans lequel il se trouve.

Il est conseillé d'utiliser des vis tamponnées en matière plastique de type fischer avec les vis de 4X40 mm, fournies avec la moustiquaire. En présence de briques percées, utiliser des vis tamponnées de dimensions appropriées avec une colle chimique.

Si les exigences de résistance nécessaires pour permettre de fixer la moustiquaire en toute sécurité ne sont pas respectées, le nombre de vis tamponnées doit être augmenté.

FAIRE ATTENTION EN MANIPULANT LA MOUSTIQUAIRE: LES ENROULEURS SONT FOURNIS AVEC LES RESSORTS CHARGES

Les instructions concernant la préparation et la mise en place de la moustiquaire se trouvent dans la boîte d'accessoires fournie en dotation.

Les éventuelles opérations de scellement doivent être effectuées avec de la résine silicique neutre.

La moustiquaire doit être fermée si la vitesse du vent atteint 20 km/h.

8. MAINTENANCE

ATTENTION: toutes les opérations de maintenance doivent être effectuées en utilisant des équipements marqués CE nécessaires pour assurer la sécurité.

8.1 Maintenance ordinaire

En raison de la qualité élevée des matériaux utilisés pour la fabrication des moustiquaires, aucune maintenance ordinaire n'est nécessaire si ce n'est l'éventuel nettoyage de la toile pour empêcher la formation de moisissures dues à un dépôt de poussières ou de tout autre matériel. La toile doit être contrôlée visuellement au moins deux fois par an ; au printemps avant l'utilisation estivale de la moustiquaire et en automne

avant de fermer cette dernière pour l'hiver.

Le nettoyage de la toile peut être effectué par aspiration de la poussière ou avec une éponge ou un chiffon humide en utilisant de l'eau tiède. Faire sécher la toile après le nettoyage et avant l'enroulement.

NE PAS utiliser de solvants, d'ammoniaque ou d'hydrocarbures pour le nettoyage.

ATTENTION: le nettoyage effectué à l'aide d'une échelle, d'un échafaudage ou autre est exclusivement réservé au personnel formé pour ce faire qui devra effectuer les opérations nécessaires dans le respect des normes de sécurité et devra utiliser les dispositifs de protection individuels requis et, si nécessaire, des harnais et des câbles de sécurité.(voir D.Lgs. 81/2008)

8.2 Maintenance extraordinaire

ATTENTION: Se référer aux instructions jointes pour l'éventuel démontage de la moustiquaire ou de parties de cette dernière.

En présence de déchirures, même de petites dimensions sur la toile, celle-ci doit être remplacée.

En cas de nécessité, utiliser des pièces de rechange originales sous peine d'annulation de la garantie.

9. GARANTIE

La garantie s'applique conformément aux contenus du D. Lgs. n. 24 du 02.02.2002. La durée de la Garantie est de 24 mois (ou plus si c'est explicitement indiqué) pour les Personnes physiques qui achètent le produit dans un but qui peut être considéré externe à leur activité professionnelle (Client privé final).

Elle est de 12 mois si le produit est facturé à une entreprise ou à un Professionnel sujet à TVA.

C'est le document fiscal de vente du produit, habituellement utilisé pour valider la garantie et en confirmer la date, qui servira également pour déterminer la durée de cette dernière.

9.1 Normes pour la validité de la Garantie

- Respecter l'usage consenti du produit.

- Respecter les instructions concernant le montage ainsi que les normes d'utilisation et de maintenance.

- Utiliser les pièces de rechanges originales Bettio Flyscreens S.r.l.

- La garantie ne sera valable que si elle est accompagnée du document de vente indiquant la date de l'achat.

9.2 Annulation de la Garantie

- Usage impropre du produit en présence de vent, pluie, grêle, neige et/ou d'autres événements climatiques associés.

- Effondrement du mur sur lequel la moustiquaire a été fixée.

- Manipulation du produit; installation, démontage, maintenance non effectués dans le respect des normes et des instructions fournies.

- Utilisation de pièces de rechange non originales Bettio Flyscreens S.r.l.

- Etiquette Bettio Flyscreens S.r.l. absente ou non visible sur le produit qui ne peut donc pas être identifié.

Pour toute autre exclusion spécifique de la Garantie se référer aux éventuelles notes fournies par l'Entreprise.

En cas de controverse, la compétence exclusive est attribuée au Tribunal de Venise.

10. EMBALLAGE, DEPLACEMENT ET TRANSPORT

La moustiquaire est emballée dans une enveloppe de polyéthylène et bloquée à l'aide de pièces en carton pour protéger ses éléments et éviter qu'ils ne bougent durant le transport. En raison des dimensions et de la forme de la moustiquaire, il est nécessaire de se mettre à deux pour la déplacer manuellement lorsque celle-ci dépasse une longueur de 240 cm.

L'emballage contient les notices de montage, d'utilisation et de maintenance

Ne pas laisser les matériaux d'emballage à la portée des enfants, ils peuvent constituer un danger pour ces derniers.

11. LISTE DES RISQUES

11.1 Installation: Adopter toutes les précautions prévues en portant une attention particulière à celles concernant les risques de chute.

11.2 Risques inhérents à l'utilisation et à la maintenance ordinaire:

Moustiquaires avec ressort de rappel:

a) Version fenêtre / porte à coulissement vertical ↓ : vitesse d'enroulement avec danger de choc contre la barre-poignée;

b) Version fenêtre / porte à coulissement vertical ↓ : vitesse d'enroulement avec danger de choc contre l'embrace;

c) Version latérale 1 battant → ou 2 battants →← : vitesse d'enroulement avec danger de choc contre la barre-poignée;

d) Risque de décrochage incontrôlé et de difficultés de fonctionnement: vitesse d'enroulement avec danger de choc contre la barre-poignée;

e) Risque de chute pendant les opérations de nettoyage de la toile: éviter de se pencher à la fenêtre et utiliser des équipements de protection appropriés.

11.3 Risques inhérents à la maintenance/réparation:

a) Risque de choc lorsque le ressort est chargé ou déchargé;

b) Risque de ne pas remettre correctement en place la moustiquaire après en avoir changé la toile.

c) Risques liés au fait de travailler sans équipements et d'utiliser des dispositifs de protection individuels non marqués CE

11.4 Risque de trébucher sur les rails de la porte à ouverture coulissante.

11.5 Risques inhérents à l'élimination: appliquer les normes en vigueur au moment de l'élimination du produit.

BENUTZUNGS- UND WARTUNGSANLEITUNG (ÜBERSETZUNG DER ORIGINALANLEITUNGEN)

1. ZWECK

Diese Anleitung ist gedacht für all diejenigen, die mit dem Fliegengitter als Installateur, Wartungspersonal, Besitzer oder Benutzer umgehen. Mit diesem Instrument möchte die Bettio Flyscreens S.r.l. dem Kunden ein Hilfsmittel für eine bewusstere und richtige Benutzung der Fliegengitter an die Hand geben, um ihre Leistungen zu verbessern und Unfälle bei der Installation und Benutzung zu vermeiden. Für eine richtige und vorteilhafte Benutzung des Systems sollten diese Hinweise daher griffbereit gehalten werden, um ein schnelles Nachschlagen immer dann zu gewährleisten, wenn die Umstände dies erforderlich machen. Sie werden unterstützt vom Bedienungs- und Wartungshandbuch und den im Unternehmen verfügbaren technischen Unterlagen.

2. GELTUNGSBEREICH

Diese Benutzungsanleitung bezieht sich auf das Modell Adriatico, für das der Inhalt angepasst wurde.

3. BEZUGSNORMEN

Diese Anweisungen wurden erstellt gemäß Punkt 1.7.4 der Richtlinie 2006/42/EWG und unter Berücksichtigung der normalen Benutzungsbedingungen des Fliegengitters, um die Monteure und Benutzer, zusammen mit den dem Zubehörbehälter beiliegenden weiteren Anweisungen zur Benutzung, auch über die Restrisiken zu informieren, die das Produkt mit sich bringt.

4. VORGEGEHENE BENUTZUNG

Das installierte System hat ausschließlich die Funktion, Schutz vor dem Eindringen von Insekten oder kleinen Tieren in die zu schützenden Räume zu bieten. Jede andere Benutzung als die angegebene ist als unsachgemäß zu betrachten und ist daher verboten, da die entsprechenden Betriebsbedingungen nicht in der vom Hersteller durchgeführten Risikoanalyse berücksichtigt wurden und es keine spezifischen Schutzvorrichtungen für sie geben könnte. Es ist verboten, sich an das Netz anzulehnen. Es ist verboten, die Griffstange loszulassen, ohne sie bis zum vollständigen Aufrollen des Netzes zu begleiten.

Die unsachgemäße Benutzung enthebt den Hersteller von jeder Verantwortung für eventuell verursachte Sach- oder Personenschäden. Die Nichtbeachtung der Benutzungsbedingungen lässt automatisch jede Art der vom Hersteller gewährten Garantie erlöschen.

5. ANFORDERUNGEN AN DEN BENUTZER

Die normale Benutzung des Fliegengitters ist einem nicht professionellen Benutzer erlaubt, wenn dieser älter als 12 Jahre ist.

Die Installations-, Reparatur- und Wartungsarbeiten müssen von Personen ausgeführt werden, die im Besitz der notwendigen technisch-praktischen Fähigkeiten für die Benutzung von auch elektrischen Ausrüstungen sind und über die unverzichtbare Sicherheit verfügen, Unfälle zu vermeiden.

6. EMPFEHLUNGEN FÜR DIE INSTALLATION

Die Installation muss alle die Personensicherheit betreffenden Vorschriften unter strengster Einhaltung der ital. Gesetzesverordnung 81/2008 sowie nachfolgender Änderungen und Ergänzungen erfolgen.

Der Installateur ist laut geltendem Gesetz verantwortlich für alles, was mit der Sicherheit des installierten Produkts zu tun hat.

Vor der Benutzung muss kontrolliert werden, dass die eventuell benutzten Werkzeuge (Bohrmaschinen, Schrauber, bewegliche Arbeitsbühnen, Arbeitsgerüste, Leitern und alle individuellen Schutzausrüstungen wie Hubgeschirre, Sicherheitsgurte, Handschuhe, Sicherheitsschuhe, Helme usw.) der Norm entsprechen und in einem guten Zustand sind.

Sollte es mehr als einen Installateur geben, müssen die Arbeiten koordiniert sowie die Aufgaben und Verantwortungsbereiche festgelegt werden. Die Installateure müssen in Übereinstimmung mit den erhaltenen und anwendbaren Sicherheitsanweisungen vorgehen. Muss das Fliegengitter in einem höheren Stockwerk als dem Erdgeschoss montiert werden, muss der Bereich während des Hochziehens des Fliegengitters zum entsprechenden Stockwerk abgegrenzt und bewacht werden, damit sich niemand unter der eventuell hängenden Last befindet.

7. INSTALLATION DER MECHANISCHEN STRUKTUR

Eine nicht korrekte Installation kann Unfälle mit Personenschaden verursachen. Lesen Sie aufmerksam die Anweisungen für die richtige Befestigung des Fliegengitters, um das Risiko eines Herunterfallens des Fliegengitters zu vermeiden.

Auf der Grundlage der dynamischen Beanspruchung, die das Fliegengitter abhängig von einer Windgeschwindigkeit von 50 km/h ausübt und die der von UNI EN 13561 beschriebenen und in Bezug auf EN 1932 festgelegten Widerstandsklasse entspricht, muss der Zustand der Mauer sichergestellt werden.

Die Wahl der Verankerungsdübel hängt ab von der Art und dem Zustand der Mauer. Es wird empfohlen, Spreizdübel aus Kunststoff vom Typ Fischer mit Schrauben 4X40 mm zu benutzen, die der Packung beiliegen. Bei Hohlsteinen sind Spreizdübel mit chemischem Kleber von angemessener Größe zu benutzen.

Werden die nötigen Widerstandsanforderungen für eine sichere Befestigung nicht eingehalten, ist die Zahl der Dübel zu erhöhen.

BEIM UMGANG MIT DEN FLIEGENGITTERN VORSICHT WALTEN LASSEN: DIE AUFROLLVORRICHTUNGEN SIND MIT GESpanNTEN FEDERN MONTIERT.

Die Anleitungen für die Vorbereitung und den Einbau sind auf dem beiliegenden Blatt beschrieben, das sich im Zubehörbehälter befindet. Eine eventuelle Versiegelung ist mit neutralem Silikonharz vorzunehmen.

Wenn die Windgeschwindigkeit 20 km/h erreicht, müssen die Fliegengitter geschlossen werden.

8. WARTUNG

ACHTUNG: Alle Wartungsarbeiten sind unter Sicherheitsbedingungen und unter Benutzung angemessener Werkzeuge mit CE-Kennzeichnung auszuführen.

8.1 Gewöhnliche Wartung

Aufgrund der hohen Qualität der beim Bau der Fliegengitter verwendeten Materialien ist keine gewöhnliche Wartung außer der eventuellen Reinigung des Tuchs vorgesehen, um es vor der Bildung von Schimmel aufgrund der Ablagerung von Staub und anderen Materialien auf dem Netz zu schützen. Das Netz muss mindestens zweimal pro Jahr einer Sichtkontrolle unterzogen werden; im Frühjahr vor der Benutzung in der Sommersaison und im Herbst vor dem winterbedingten Schließen. Für die Reinigung kann der Staub vom Netz abgesaugt werden oder es kann mit einem mit lauwarmem Wasser befeuchteten Schwamm oder Lappen gereinigt werden. Das Netz nach der Reinigung und vor dem Aufrollen trocken lassen. Für die Reinigung KEINE Lösungsmittel-Ammoniak-Kohlenwasserstoffe benutzen.

ACHTUNG: Die mit Hilfe von Leitern, Arbeitsbühnen oder anderen Hilfsmitteln ausgeführte Reinigung darf nur von Personal durchgeführt werden, das im Besitz der geeigneten Fähigkeiten ist und das die Arbeiten unter Einhaltung der Sicherheitsvorschriften und unter Benutzung der angemessenen persönlichen Schutzausrüstung und eventuell auch von Sicherheitsgeschirren mit Halteseilen ausführen muss (siehe ital. Gesetzesverordnung 81/2008).

8.2 Außergewöhnliche Wartung

ACHTUNG: Für die eventuelle Abmontage des Fliegengitters oder von Teilen des Fliegengitters ist Bezug zu nehmen auf die beiliegenden Anweisungen. Bei auch nur kleinen Rissen im Netz müssen die Fliegengitter ausgetauscht werden.

Im Bedarfsfall Originalersatzteile benutzen, da anderenfalls die Garantie erlischt.

9. GARANTIE

Die Garantie wird angewandt in Bezug auf den Inhalt der ital. Gesetzesverordnung Nr. 24 vom 02.02.2002. Die Dauer der Garantie beträgt 24 Monate (oder mehr, wenn ausdrücklich angegeben) für natürliche Personen, die das Produkt zu Zwecken erwerben, die als außerhalb ihrer beruflichen Tätigkeit liegend betrachtet werden können (privater Endkunde).

Sie beträgt 12 Monate, wenn das Produkt einem mehrwertsteuerpflichtigen Unternehmen oder Berufsgruppe in Rechnung gestellt wird.

Da es üblich ist, das steuerliche Verkaufsdokument für die Gültigmachung und Datumsbestimmung der Garantie zu benutzen, bestimmt selbiges Dokument die Dauer des Garantiezeitraums.

9.1 Vorschriften für die Gültigkeit der Garantie

- Die für das Produkt zulässige Benutzung einhalten.
- Die Montageanweisungen sowie Benutzungs- und Wartungsvorschriften beachten.
- Originalersatzteile der Bettio Flyscreens S.r.l. benutzen.
- Die Garantie ist nur dann gültig, wenn sie von einem Verkaufsbeleg begleitet wird, der das Kaufdatum bestätigt.

9.2 Erlöschen der Garantie

- Unsachgemäße Benutzung des Produkts bei Wind, Regen, Hagel, Schnee und/oder anderen kombinierten Ereignissen.
 - Nachgeben der Mauer, an der das Produkt befestigt ist.
 - Fremdeinwirkung am Produkt; nicht nach den Vorschriften und vorliegenden Anweisungen ausgeführte Installation, Abmontage, Wartung.
 - Benutzung von Ersatzteilen, bei denen es sich nicht um Originalersatzteile der Bettio Flyscreens S.r.l. handelt.
 - Entfernung oder Abdeckung des Identifikationsschildes Bettio Flyscreens S.r.l., wodurch die Rückverfolgbarkeit des Produkts nicht möglich ist.
- Für weitere spezifische Ausschlüsse von der Garantie ist Bezug zu nehmen auf eventuell vom Unternehmen angegebene Hinweise. Für alle Streitigkeiten ist ausschließlich der Gerichtsstand Venedig zuständig.

10. VERPACKUNG, HANDHABUNG UND TRANSPORT

Das Fliegengitter besitzt eine Verpackung aus Polyethylen mit Pappprofilen, um die Komponenten beim Transport zu schützen und festzustellen. Aufgrund der Abmessungen und der Form des Produkts ist es notwendig, dass bei einem Längenmaß von mehr als 240 cm die manuelle Handhabung durch zwei Personen erfolgt.

Die Verpackung enthält die Montage-, Benutzung- und Wartungsanleitung.

Das Verpackungsmaterial nicht in die Hände von Kindern gelangen lassen, da es eine Gefahrenquelle für sie darstellen kann.

11. RISIKOLISTE

11.1 Installation: Alle vorgesehenen Vorsichtsmaßnahmen unter besonderer Berücksichtigung der Maßnahmen hinsichtlich der Sturzgefahr anwenden.

11.2 Risiken im Zusammenhang mit der Benutzung und normalen Wartung:

Fliegengitter mit Rückholfeder:

- a) Ausführung Fenster / Tür mit vertikalem Lauf : Aufrollgeschwindigkeit mit der Gefahr des Zusammenstoßes mit der Griffstange;
- b) Ausführung Fenster / Tür mit vertikalem Lauf : Aufrollgeschwindigkeit mit der Gefahr des Zusammenstoßes mit der Troddel;
- c) Seitliche Ausführung 1 Flügel oder 2 Flügel : Aufrollgeschwindigkeit mit der Gefahr des Zusammenstoßes mit der Griffstange;
- d) Gefahr des unkontrollierten Lösens und der Funktionszweideutigkeit: Aufrollgeschwindigkeit mit der Gefahr des Zusammenstoßes mit der Griffstange;
- e) Gefahr des Herunterfallens während der Netzreinigungsarbeiten: Herauslehnen aus dem Fenster vermeiden und eine angemessene Ausrüstung benutzen.

11.3 Risiken im Zusammenhang mit der Wartung/Reparatur:

- a) Stoßgefahr während der Arbeiten für das Spannen/Lösen der Feder;
- b) Gefahr der nicht korrekten Wiederherstellung des Fliegengitters beim Netzwechsel;
- c) Gefahr durch die Benutzung von Werkzeugen und PSA ohne CE-Kennzeichnung.

11.4 Gefahr des Stolperns über die Führung der Tür mit Seitenöffnung.

11.5 Risiken im Zusammenhang mit der Entsorgung: Die Entsorgung des Produkts muss auf der Grundlage der aktuell gültigen Vorschriften durchgeführt werden.